

LTE910CF CAT1 Embedded Cellular Modem User Manual

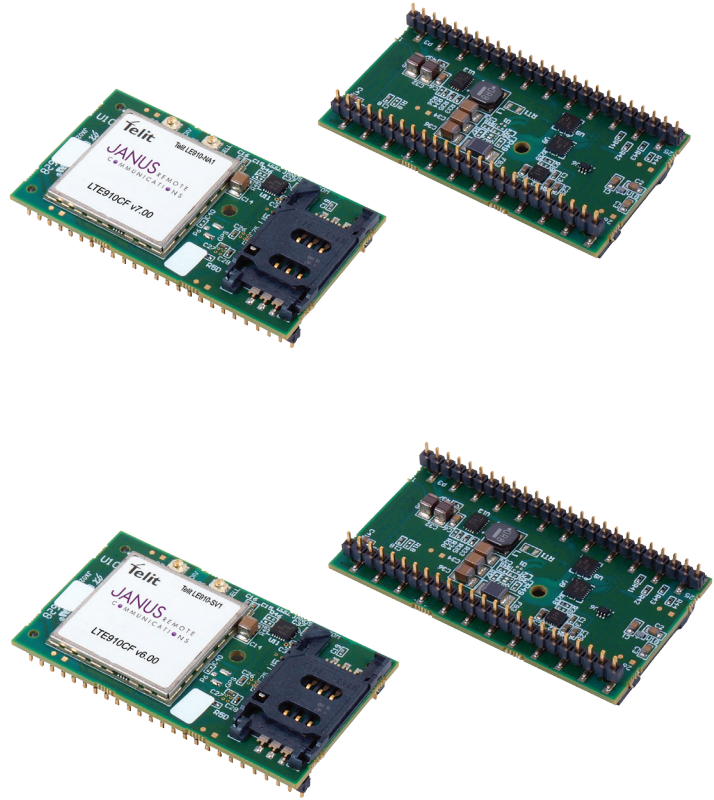

JANUS REMOTE
COMMUNICATIONS

Bulletin	JA03-UM-LTE-Cat1
Revision	P02
Date	19 Nov 2019

TABLE OF CONTENTS

TABLE OF CONTENTS and DISCLAIMER.....	2
1 APPLICABILITY TABLE.....	3
2 REFERENCES.....	3
2.1 Janus Document List.....	3
2.2 Telit Document List.....	3
3 OVERVIEW.....	4-6
3.1 Introduction.....	4
3.2 Preview.....	4
3.3 LTE Features.....	5
3.4 LTE Block Diagram.....	5
3.5 FOTA Notice.....	6
4 INTERFACES.....	6-15
4.1 Interface Voltage Selection.....	6
4.2 Serial Interface.....	7-8
4.3 Power Supply.....	9
4.4 Audio Interface.....	9
4.5 Plug-In Pin-Out.....	10
4.6 VRTC Details.....	11
4.7 GPIO Details.....	12
4.8 Analog to Digital Converter.....	13
4.9 LED Status Indicators.....	13-14
4.10 RF Interface.....	15
4.11 SIM Card Interface.....	15
4.12 Header Interface Mounting Options.....	15
4.13 Screw Mounting.....	15
5 LTE910CF TECHNICAL SPECIFICATIONS.....	16-23
5.1 Electrical Specifications.....	16-19
5.2 Mechanical Specifications.....	20
6 OPERATIONS.....	21-24
6.1 Powering ON/OFF.....	21
6.2 Communicating with the modem.....	21
6.3 Testing Communications.....	21
6.4 Cellular Network Communications.....	22
6.5 Data Communications.....	23
6.6 SMS.....	24
7 DESIGN CONSIDERATIONS.....	25
7.1 Minimum Required Module Pin Connects.....	25
7.2 Debug.....	25
APPENDICES.....	25
Approvals.....	25
Safety.....	25
Antenna Care and Replacement.....	25
Abbreviations.....	25
Ordering Information.....	26
Revision History.....	26

DISCLAIMER

The information contained in this document is the proprietary information of Connor-Winfield Corporation and its affiliates (Janus Remote Communication). The contents are confidential and any disclosure to persons other than the officers, employees, agents or subcontractors of the owner or licensee of this document, without the prior written consent of Connor-Winfield, is strictly prohibited. Connor-Winfield makes every effort to ensure the quality of the information it makes available. Notwithstanding the foregoing, Connor-Winfield does not make any warranty as to the information contained herein, and does not accept any liability for any injury, loss or damage of any kind incurred by use of or reliance upon the information. Connor-Winfield disclaims any and all responsibility for the application of the devices characterized in this document, and notes that the application of the device must comply with the safety standards of the applicable country, and where applicable, with the relevant wiring rules. Connor-Winfield reserves the right to make modifications, additions and deletions to this document due to typographical errors, inaccurate information, or improvements to programs and/or equipment at any time and without notice. Such changes will, nevertheless be incorporated into new editions of this application note.

All rights reserved 2019 Connor-Winfield Corporation

1 APPLICABILITY TABLE

Product	Part Number
LTE910CF	v6.00
LTE910CF	v7.00

2 REFERENCES

2.1 Janus Document List

Janus Application Note 117 - FOTA (Firmware Over The Air)

2.2 Telit Document List

Our modem uses Telit LE910-NA1 cellular module.

Please refer to Telit's website at www.telit.com for the latest information on the LE910 V2 module family.

Telit LE910 V2 AT Commands Reference Guide

Telit LE910 V2 Hardware User Guide

Telit IP Easy User Guide

Telit 3G-4G Digital Voice Interface Application Note

3 OVERVIEW

3.1 Introduction

The User Manual for the Plug-In Modem devices is intended to illustrate how users can integrate and implement the features of each communication version of the device. The common factors are explained in detail, as well as special considerations and diagrams for each module. The module differences are highlighted in this manual for design considerations for future model placement.

3.2 Preview

The Plug-In Modems are self-contained, multi-band, globally capable, M2M communication devices designed to provide a comprehensive solution to application problems for our M2M customers. They utilize the proven technology of Telit's certified modules for their core communications engines.

3.2.1 Functional Description

Cellular

- LTE (V6.00)
- LTE/HSPA/UMTS (V7.00)

UART

- 115200 bps supporting all 7 standard RS232 signals

USB

- HS/FS USB 2.0 Device (480Mb/s)

Physical Dimensions

- Length and width of all Plug-In devices are equal
- Heights of different devices will vary

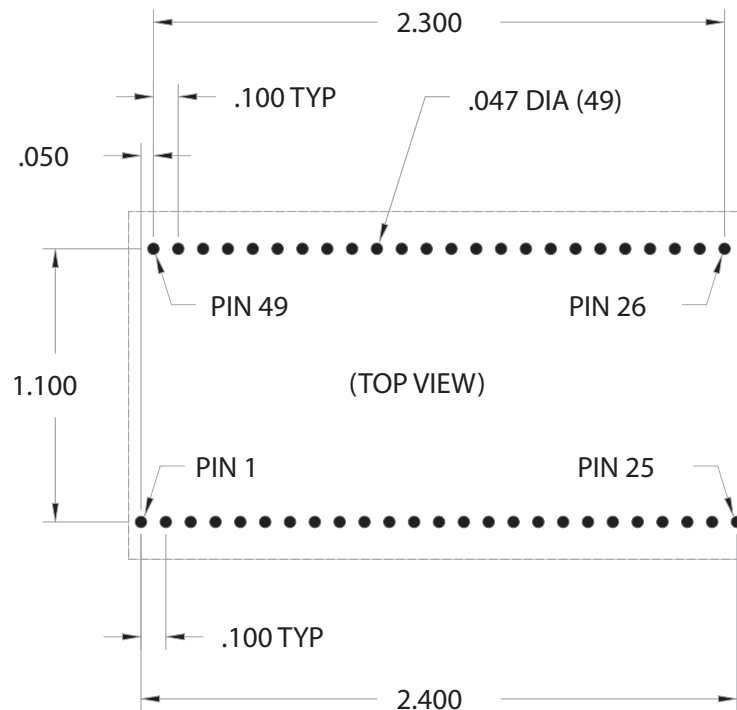

3 OVERVIEW continued

3.3 Features

LTE910CF v7.00 (AT&T)

- Multi-Band Support
LTE Band 1900 (B2), 1700 (B4), 850 (B5), 700 (B12/B13)
UMTS/HSPA+ Band 850 (B5), 1900 (B2)
- Output Power
Class 3 (0.2W) @ LTE
Class 3 (0.25W) @ WCDMA
- Data
LTE: DL: Up to 10Mbps, UL: Up to 5Mbps
HSPA: DL: Up to 42Mbps, UL: Up to 5.76 Mbps
UMTS: DL: Up to 384Kbps, UL: Up to 384Kbps

LTE910CF v6.00 (Verizon)

- Tri-Band Support
LTE Band 1900 (B2), 1700 (B4), 700 (B13)
- Output Power
Class 3 (0.2W, 23dBm) @ LTE
- Data
LTE: DL: Up to 10Mbps, UL: Up to 5Mbps

Features for Both v6.00 & v7.00

- Control via standard and extended AT command set
- SIM application Tool Kits 3GPP TS 51.014
- SIM access profile
- IP stack with TCP/UDP protocol support
- SMS Support
- Through hole for screw mount
- Dimensions: 2.5" x 1.4" x 0.325"
- Operational Temperature Range: -40°C to 85°C
- Internal Switching Regulator:
Input Voltage Range: 4.75 to 5.25Vdc (5Vdc nominal)
Supply disable via terminal input pin
- Variable logic level (UART/GPIO)
Adjustable from 1.8 - 5.0Vdc
Defaults to 2.85v
- SIM Card
Standard locking SIM card socket
- Cellular, Rx Diversity & MIMO DL 2x2 antenna connections via Hirose U.FL miniature RF connectors

3.4 Block Diagram

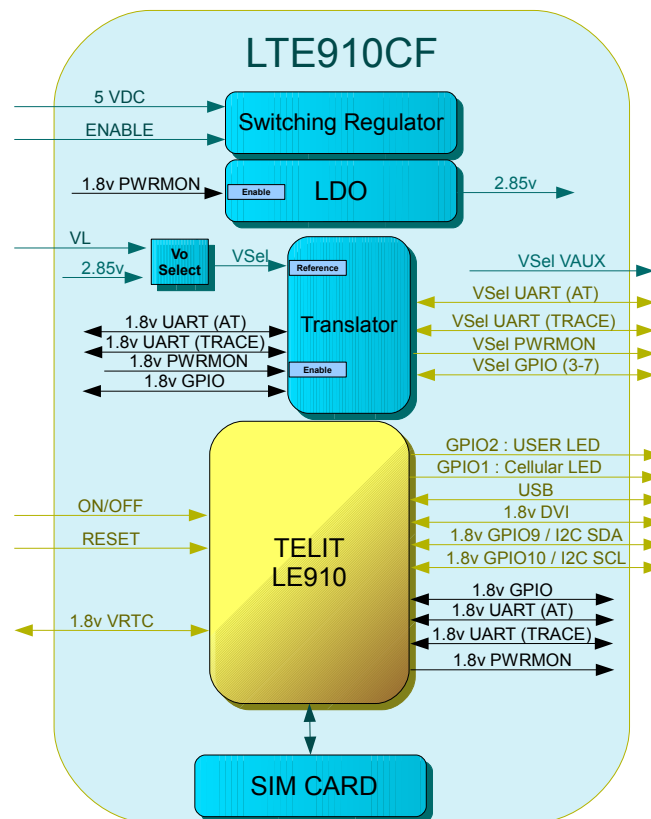

Figure 1 LTE910CF CAT1 Block Diagram

3 OVERVIEW continued

3.5 FOTA Notice

The certification of LTE devices for use on the Verizon Wireless network REQUIRES that the end user implement an automated FOTA procedure on their devices that would allow the cellular module firmware to be updated if required.

Failure to implement an automated FOTA procedure violates the certification requirements of the cellular modem and may result in units becoming unusable on the cellular network in the future. Your end device must support the firmware over the air update for the cellular modem

You may use your own FOTA system to update the cellular modem firmware over the air. You may also be able to use the Verizon Wireless FOTA system, and FOTA services may be available from other 3rd party vendors.

To inquire about Verizon Wireless FOTA system information and technical specifications, contact VZW.FOTA-Services@VerizonWireless.com

4 INTERFACES

4.1 Interface Voltage Selection

The LTE910CF is equipped with a variable voltage interface solution. This allows the user to match the device to the system's level without extra hardware. Once a voltage has been injected, the unit will swap to the chosen voltage immediately for the affected I/O.

The VL_IN signal can be applied or changed to a different level within the 1.5V to 5.5V operational range after the unit is powered, but once applied the VL_IN voltage should not be removed unless the unit is turned off.

If no external reference is applied to the VL_IN pin, the I/O interface will default to a 2.85V level. In this case the VL_IN pin 30 should be pulled low.

Truth Table:

VL_IN:	Ground	1.5v - 5.5v
I/O level:	2.85v	1.5v - 5.5v

Affected I/O:

1. UART (AT, TRACE)
2. GPIO (3-7)
3. VAUX

VAUX Adjustment allows feedback as well as legacy access if previously utilizing a plug in implementation with VAUX as the reference.

Note to pay attention of these changes so there are no adverse effects on a previous Plug in Modem implementation.

4 INTERFACES

4.2 Serial Interface

4.2.1 UART Serial Port

The serial interface is a CMOS level UART. Default Communications settings for this port are as follows:

- Baud Rate: 115.2 kbps
- Bits: 8
- Stop Bits: 1
- Parity: None
- Hardware Handshaking: Yes

Baud rate can be controlled with the AT+IPR command. Default setting is 115200 baud.

Note: If you are not using hardware handshaking, RTS must be connected to GROUND for proper communications when flow control is not used.

4.2.1.1 UART Level Translation

The electrical limits for the UART are listed in the electrical characteristics section. Please be aware of these limits, as operating outside of them may damage the unit. If the limits must be exceeded, level translation can be used.

An example of basic translation for RXD/TXD only is found below.

Although an external source for the level translation can be used, VAUX can be used as the reference instead.

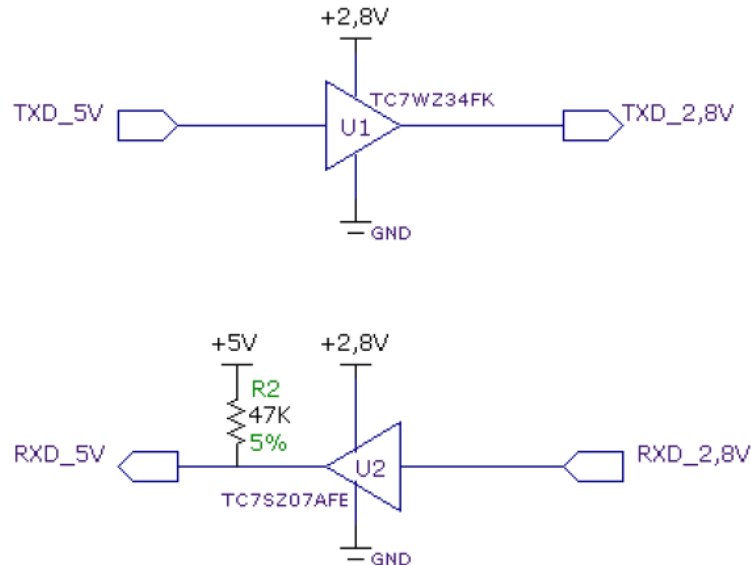

Figure 2 UART Level Translation Example

However, because some Plug-In Modems require AT commands to control VAUX, PWRMON may be used as an enable to an external reference. Do not use PWRMON directly as the reference.

Note that the UART Level Translation example remains in this guide for legacy purposes when designing a system for multiple Plug in Modems. The LTE910CF is equipped with interface voltage adjustment, negating the need for translation.

4.2.2 USB Port

The Plug-In modems that are USB ready include an integrated universal serial bus (USB) transceiver, compliant with USB 2.0 specifications. High data rates for the USB enabled modems are only available over the USB interface, as the UART has a maximum baud rate of <1Mbps. In order for proper power-up of the Plug-In Modems, the USB_VBUS line MUST be disconnected until the unit is otherwise fully powered and on. If the USB_VBUS line is attached and powered before the main power is brought up and the module turned on, power sequencing issues may occur.

Note: You must implement the USB interface in order to locally update module firmware.

4 Interfaces continued

4.2.2 USB Port continued

4.2.2.1 USB Connection Diagram

When VBUS_ENABLE is HIGH the VBUS 5.0v signal will be passed to USB_VBUS, (pin 29) turning the USB ON.

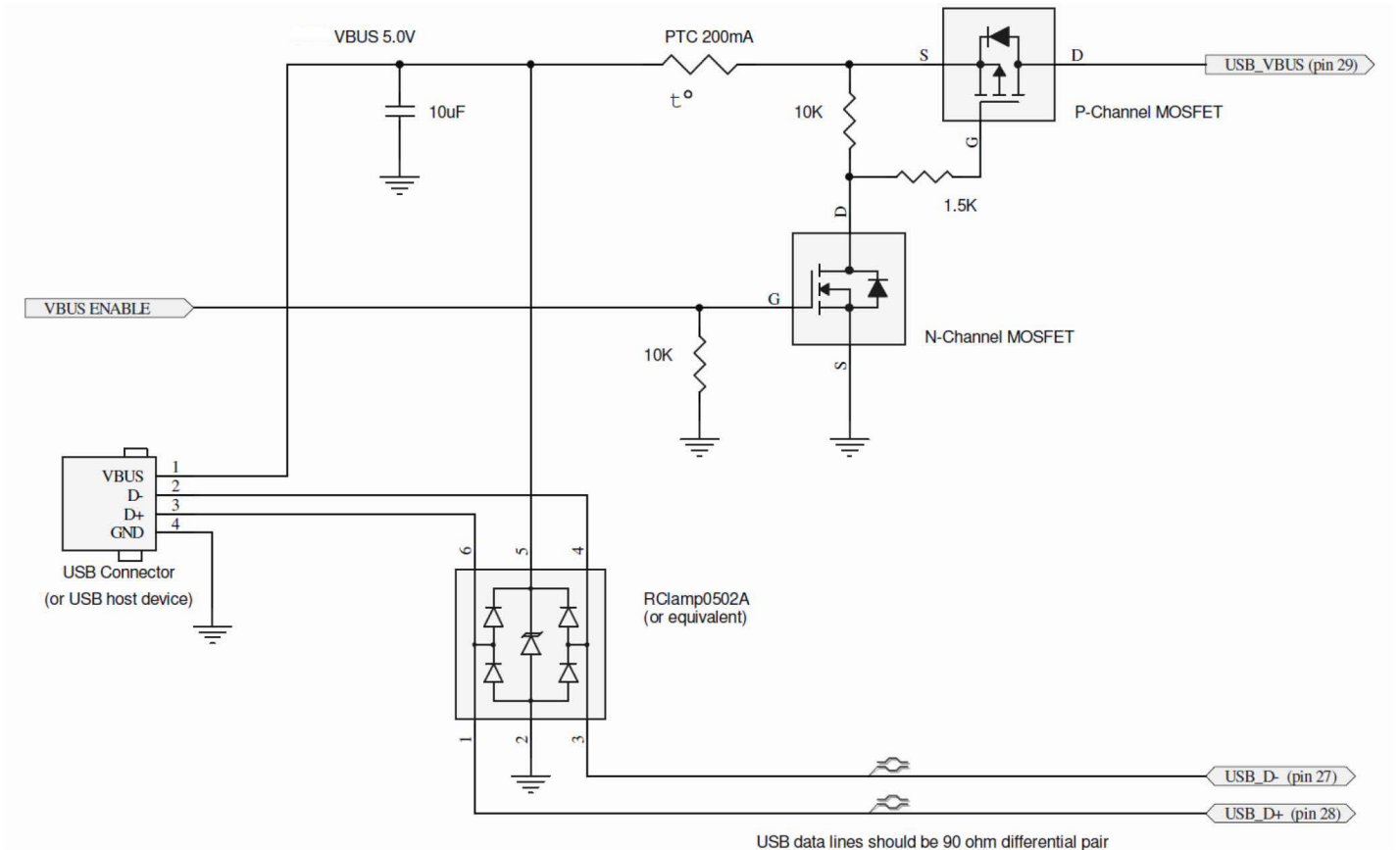

Figure 3 USB Connection Diagram

4 Interfaces continued

4.3 Power Supply

The module's power supply accepts input voltages from 4.75Vdc to 5.25Vdc and requires a nominal current sourcing capacity of 5W (maximum 10W).

Power Supply

A good understanding of the load transients is required in order to meet the power requirements of a cellular radio. Power supply design, thermal management and layout are outside the scope of this document. Please refer to power supply manufacturers for product documentation and design application notes.

Cellular Load Transients

Cellular radios use a mix of modulation schemes including, but not limited to, TDMA and CDMA. In GSM/GPRS systems the transmission and reception of data is achieved via Time Division Multiple Access (TDMA). TDMA transmission is made up of RF bursts that cause 2A current pulses at the supply input of the cellular radio. These current pulses occur at a frequency of 216 Hz and can persist for 1.2 to 2.4ms.

On Board Regulator

This Plug-In module is designed with a switching regulator to power the cellular radio. The regulator can receive an input voltage of 4.75 to 5.25VDC.

Note: The regulator input is capable of withstanding 6VDC Maximum. This is outside the recommended operating voltage of the Plug-In modules but but is helpful to know when designing input transient circuitry.

Plug-In Module Input Supply Requirements

The current values are given in average units due to the pulsed nature of the transmission scheme. It is recommended that your supply source the full peak current value of the transmission pulse in order to maintain proper cellular operation. The use of bulk output capacitors on your supply allows for a less powerful supply.

4.4 Audio Interface

The LE910CF modules use a DVI audio interface that supports PCM master mode and can use a CODEC to convert the interface to analog. Below is a block diagram based on DVI and the MAX9867 CODEC with GPIO 9 and 10 being used for I2C control of the CODEC. Please refer to the referenced DVI Application Notes for full information.

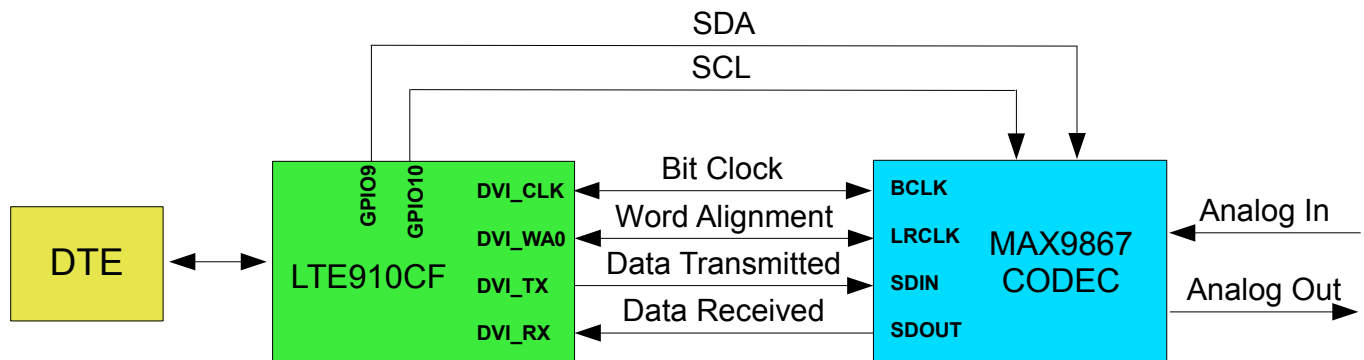

Figure 4 DVI Block Diagram

4 Interfaces continued

4.5 Plug-In Pin-Out

PIN	PIN NAME	DESCRIPTION	STANDARD I/O SIGNAL	POWER-ON STATE	PULL TYPE	NOTE
1	SUPPLY	Positive Supply Input	Power	N/A	N/A	
2	SUPPLY	Positive Supply Input	Power	N/A	N/A	
3	ENABLE SUPPLY	Enable/Disable Supply	Input	N/A	PULL-UP to Vin: 681k	1
4	RXD	UART - Transmit Line	Output	N/A	N/A	6
5	DSR	UART - Data Set Ready	Output	N/A	N/A	6
6	CTS	UART - Clear to Send	Output	N/A	N/A	6
7	RING	UART - Ring Indicator	Output	N/A	N/A	6
8	DCD	UART - Data Carrier Detect	Output	N/A	N/A	6
9	TXD	UART - Receive Line	Input	N/A	N/A	6
10	DTR	UART - Data Terminal Ready	Input	N/A	N/A	6
11	RTS	UART - Request to Send	Input	N/A	N/A	4
12	GROUND	Supply Reference	Power	N/A	N/A	
13	TRACE_TX	Debug UART - Transmit Line	Output	N/A	N/A	6
14	TRACE_RX	Debug UART - Receive Line	Input	N/A	N/A	6
15	GPIO_2	General Purpose I/O - User LED	Output	N/A	N/A	6
16	GPIO_1/STATUS	General Purpose I/O - Status LED	Output	N/A	N/A	6
17	SERVICE	Unused	N/A	N/A	N/A	5
18	PWRMON	Power Monitor Output	Output	N/A	PULL-DOWN:1M	6
19	ON_OFF	Toggle Cellular Radio On Off State	Input	N/A	PULL-UP to VTRC: 47k	1
20	RESET	Reset Cellular Radio	Input	N/A	PULL-UP: 47k	1
21	DVI WAO	DVI Word Alignment	WCLK	N/A	N/A	6
22	DVI RX	DVI Received Data	SDIN	N/A	N/A	6
23	DVI TX	DVI Transmitted Data	SDOUT	N/A	N/A	6
24	DVI CLK	NDVI Data Clock	BCLK	N/A	N/A	6
25	GROUND	Supply Reference	Power	N/A	N/A	
26	GROUND	Supply Reference	Power	N/A	N/A	
27	USB_D-	USB Differential Data (-)	CMOS Bi-Direction	N/A	N/A	
28	USB_D+	USB Differential Data (+)	CMOS Bi-Direction	N/A	N/A	
29	USB_VBUS	USB Supply	Power	N/A	N/A	
30	VL_IN	Interface Voltage Reference	Analog Input	N/A	PULL-DOWN: 7M	3
31	GPIO_9	General Purpose I/O	CMOS Bi-Direction	INPUT	N/A	
32	GPIO_10	General Purpose I/O	CMOS Bi-Direction	INPUT	N/A	
33	GPS_RX	Unused	N/A	N/A	N/A	5
34	GPS_TX	Unused	N/A	N/A	N/A	5
35	GPS_RESET	Unused	N/A	N/A	N/A	5
36	GPIO_7	General Purpose I/O	Bi-Direction	INPUT	N/A	6
37	GPIO_6	General Purpose I/O	Bi-Direction	INPUT	N/A	6
38	GPIO_5	General Purpose I/O	Bi-Direction	INPUT	N/A	6
39	GROUND	Supply Reference	Power	N/A	N/A	
40	GPIO_4	General Purpose I/O	Bi-Direction	INPUT	N/A	6
41	GPIO_3	General Purpose I/O	Bi-Direction	INPUT	N/A	6
42	Legacy GPIO_2	Unused	N/A	N/A	N/A	5
43	Legacy GPIO_1	Unused	N/A	N/A	N/A	5
44	DAC	Unused	N/A	N/A	N/A	5
45	ADC2	Unused	N/A	N/A	N/A	5
46	ADC1	Analog to Digital Converter	Analog Input	N/A	N/A	6
47	VRTC	Unused	Unused	N/A	N/A	5
48	VAUX	Reference Voltage	Analog Output	N/A	N/A	
49	GROUND	Supply Reference	Power	N/A	N/A	

Notes:

1. It is required that this input be controlled by an Open Collector/Drain Output. Do not use an external pull-up resistor; a pull-up is included internal to the module.
2. Not currently implemented.
3. VL_IN should be grounded if not being used.
4. RTS must be connected to GROUND if flow control is not used.
5. Not used on the v6.00 and v7.00.
6. Refer to the electrical specifications for I/O levels.

4 Interfaces continued

4.6 VRTC Details

The VRTC pin brings out the real time clock supply, which is separate from the rest of the part. This allows only the RTC to be ON when all other parts of the device are OFF. A backup capacitor can be added to this pin to increase RTC autonomy while powering the device from a battery.

No devices should be powered from this pin.

Equations:

$$C = 3600 * [(Btime * IRTC)/(VRTC - VRTCmin)]$$

$$Btime = [C * (VRTC - VRTCmin)/(IRTC * 3600)]$$

Where:

VRTC – The Starting voltage of the capacitor (Volt)

VRTCmin – The minimum voltage acceptable for the RTC circuit. (Volt)

IRTC – The current consumption of the RTC circuitry when VBATT = 0 (Ampere)

Btime - Backup Time (Hours)

C = Capacitor value (Farads)

Values for the LTE910CF

VRTC = 1.8v Nominal

VRTC minimum input voltage to function = 1.1v

IRTC = 2uA nominal

For Example,

Btime = 96 hours (4 days)

C = 1.0F

4 Interfaces continued

4.7 GPIO Details

GPIO are configurable as input, output, and alternate function. Configuration is controlled by AT commands. Alternate functions include cellular status, ALARM pin function, temperature monitor indication and DAC output.

4.7.1 Using a GPIO Pad as INPUT

The GPIO pads, when used as inputs, can be connected to a digital output of another device and report its status, provided this device has interface levels compatible with the Voltage levels of the GPIO of the module.

4.7.2 Using a GPIO Pad as OUTPUT

The GPIO pads, when used as outputs, can drive CMOS digital devices or compatible hardware. When set as outputs, the pads have a push-pull output.

4.7.3 Cellular Status LED (GPIO1)

The LED Status output is used to drive an external LED to give feedback on the current operation. See figure 5 for recommended connection of an LED. For the LTE910CF, this is an alternate function of GPIO1 and must be set via the AT#GPIO command. The status is defined below.

Cellular Status Indication

LED Status	Device Status
Off	Cellular radio is off
On	On/Searching
Slow Blinking (0.3 sec on / 2.7 sec off)	Registered

4.7.4 User LED (GPIO2)

This module has GPIO2 connected to the User LED pin of the Modem. The user application can use this to control an LED or act as an additional GPIO. See figure 5 for recommended connection of an LED.

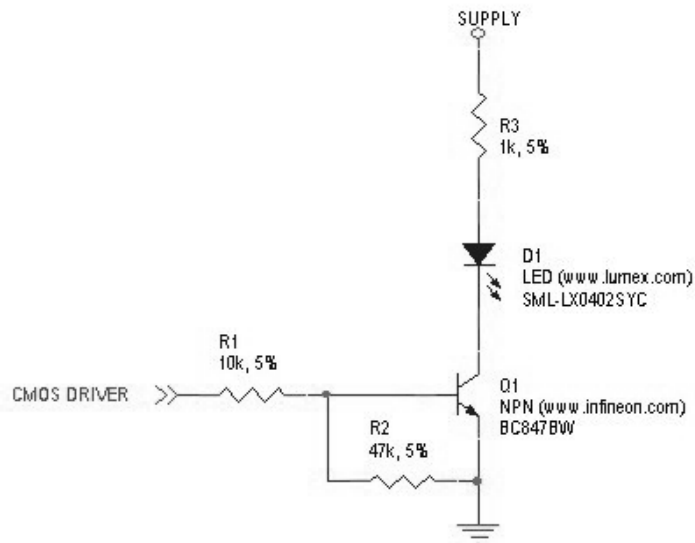

Figure 5 LED Indicators Diagram

4.7.5 I2C

The I2C interface is an alternate function of the modem's GPIO pins. The I2C SCL clock and I2C SDA data signals are assigned using the AT#I2CRD and AT#I2CWR commands.

To maintain compatibility with legacy modems the GPIO 9 (SDA) and GPIO 10 (SCL) pins should be used. These pins are 1.8V logic level to match the DVI interface for easy usage with a codec.

The signals are not pulled up on the Plug-In module and must be pulled up externally for use as an I2C bus. Please reference the Telit AT Command Guide for details on the I2C commands.

4 Interfaces continued

4.8 Analog to Digital Converter

Pin 46 is connected directly to the Telit module ADC pin. It has a 0 to 1.2V range with 10 bit resolution. Use the command `AT#ADC=1.2<cr>` to read the ADC. The returned value is expressed in millivolts.

ADC	Description
ADC1	Analog to digital converted input

4.9 Internal Interfaces

4.9.1 ENABLE pin

Input Logic State	Description
High-Z	Active state
0	Shutdown

Notes:

1. It is required that this input be controlled by an open collector/drain output. Do not use an external pull-up resistor, a pull-up to VIN is included internal to the Modem.
2. The ENABLE pin is offered as a means to turn off the on-board regulator for when a full power cycle is needed or an ultra low power state is required. The ENABLE pin is not intended to be used as a means of turning the Modem off. use the ON/OFF pin to turn the Modem on or off.
3. Shut down state must be held for 10ms before returning to active state.
4. The regulator is operational 2mS after active state is entered.

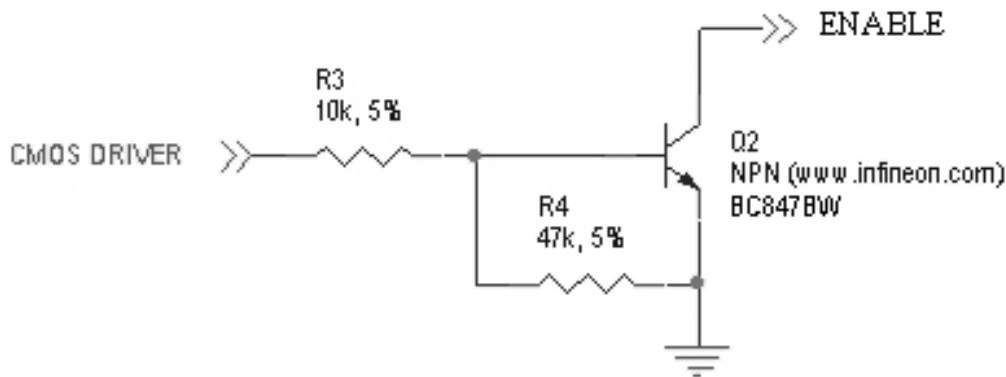

Figure 6 Enable Pin

4.9.2 RESET Pin

Input Logic State	Description
High-Z	Active state
0	Reset state

Notes:

1. It is required that this input be controlled by an open collector/drain output. Do not use an external pull-up resistor, a pull-up is included internal to the Modem.
2. The RESET pin is offered as a means to reset the Modem when and if the Modem becomes unresponsive. The RESET pin is not intended to be used as a means of turning the Modem off. Use the ON/OFF pin to turn the Modem on or off.
3. RESET state must be held for at least 200ms before returning to active state.

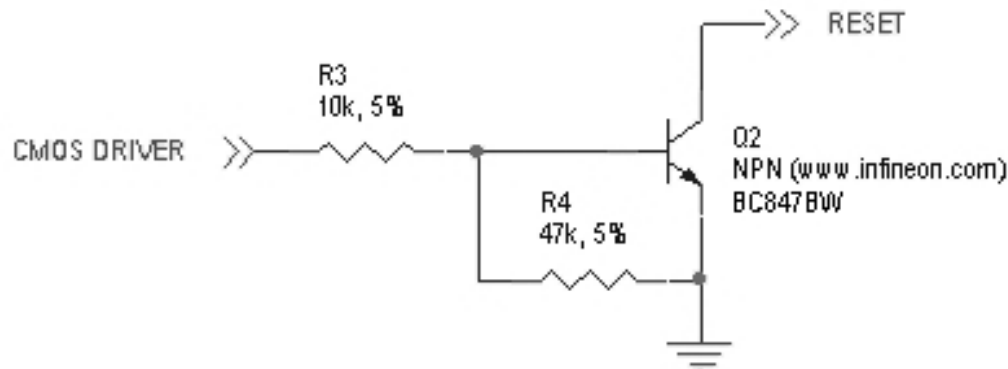

Figure 7 Reset Pin Diagram

4 Interfaces continued

4.9 GPIO Details continued

4.9.3 ON/OFF Pin

Input Logic State	Description
High-Z	Modem turned ON or OFF after input returns to this state.
0	Toggle Modem ON or OFF

Notes:

1. It is required that this input be controlled by an open collector/drain output. Do not use an external pull-up resistor, a pull-up is included internal to the Modem.
2. The ON/OFF pin is offered as a means to power-on and power-down the Modem. When the Modem powers-down it informs the cell tower that it is powering down and will not be communicating with the tower any more. This is considered a controlled power-down.
3. After toggling the power state of the Modem, wait until PWRMON indicates chosen state before toggling the power state again.
4. To turn ON the plug-in module, the ON_OFF input must be tied low for 5 seconds then released.
5. To turn OFF the plug-in module, the ON_OFF input must be tied low for 3 seconds then released.
6. Optionally the Modem may be powered-down with the use of AT commands.
7. It is required to stop driving terminal inputs high when turning ON the Plug-In module by floating or bringing them low. If this is not done, power sequencing issues may occur.

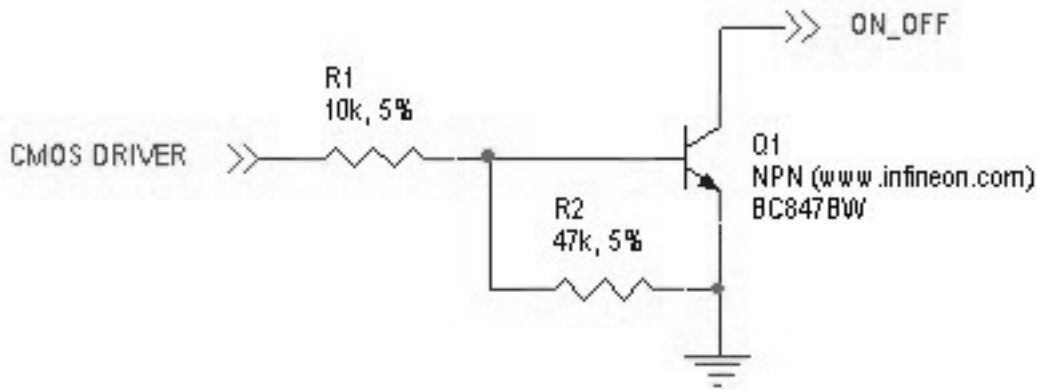

Figure 8 On / Off Pin Diagram

4.9.4 PWRMON Pin

Output Logic State	Description
0	Modem powered-down
1	Modem powered-on

Notes:

1. Used in conjunction with ON/OFF pin to control power-on and power-down state.
2. During a power down, it is required to stop driving terminal inputs high by floating or bringing them low. If this is not done, the PWRMON output will not transition low. On the GSM865CF and LTE910CF, this will cause the VAUX output to remain active.

4.9.5 VAUX Pin

A regulator power supply output that is provided in order to supply small devices from the module itself.

When PWRMON is HIGH, VAUX will be ON. When PWRMON is LOW, VAUX will be OFF. On the LTE910CF, the VAUX signal voltage will match to the VL IN voltage if utilized.

4 Interfaces continued

4.10 RF Interface

There are two RF interfaces on the LTE910CF. A cellular and MIMO/RX diversity connector. The specifications and requirements for these are as follows:

4.10.1 LTE910CF Antenna Interface

Type: Hirose U.FL - MALE (Part Number: U.FL-R-SMT(10))

Pin	Description
Center Pin	RF signal
Outer Conductor	Signal ground

4.11 SIM Card Interface

The SIM Card Interface allows the Modem to accept the subscriber card provided by the cellular telephone provider. It can accommodate a 1.8v or 3.0v SIM card.

4.12 Header Interface Mounting Options

The Plug-In Modules' header pin length has been chosen to allow for direct solder mount to a PCB of standard thickness. If the user wishes to socket the Plug-In Module, they may do so as well by using the below part numbers for reference:

Samtec 25 pin header: TSM-125-04-L-SV-A

Samtec 24 pin header: TSM-124-04-L-SV-A

Mating Samtec 25 pin connector: SLW-125-01-G-S

Mating Samtec 24 pin connector: SLW-124-01-G-S

Please note there are no Samtec SMT single row mating connectors. The only mating connector available is the above listed THT version.

4.13 Screw Mounting

The LTE910CF allows for the use of a #4 machine screw to help keep a socketed module in place where environmental variables may cause problems otherwise. If the user wishes to have a stand-off underneath the module to help alleviate possible stress from mounting hardware, below are the Janus part numbers and associated drawings for an available solution.

4-40 Hex Female Stand-off: MC-0356-G

4-40 3/16" Pan Head Phillips Machine Screw: MC-0357-G

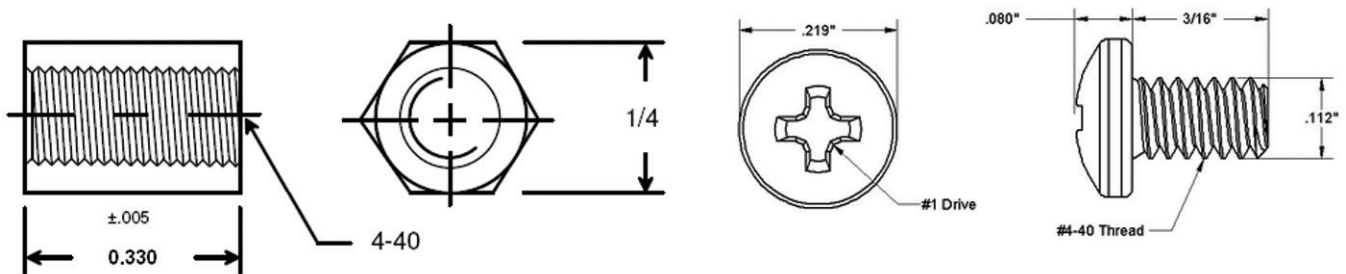

Figure 9 Screw Diagram

5 LTE910CF TECHNICAL SPECIFICATIONS

5.1 Electrical Specification

5.1.1 Absolute Maximum Ratings

Parameter	Min	Typ	Max	Unit	Note
VIN (DIGITAL INPUTS 2.85V CMOS)	-0.5	-	3.35	Volt	
VIN (DIGITAL INPUTS 1.8V CMOS)	-0.3	-	3.1	Volt	
VIN (Digital Inputs VL Selected)	-0.3	-	5.5	Volt	
Storage Temperature	-40	-	85	°C	
Supply (+) referenced to Supply (-)	0	-	6	Volt	

Operation of the device at these or any other conditions beyond those listed under Recommended Operating Conditions is not implied. Exposure to Absolute Maximum Rating conditions for extended periods of time may affect device reliability.

5.1.2 Recommended Operating Conditions

Parameter	Min	Typ	Max	Unit	Note
Temperature	-40	-	85	°C	
Supply (+) referenced to Supply (-)	4.75	5.0	5.25	Volt	
VL IN Selection	1.8	-	5.0	Volt	
VAUX Output	-	2.85	-	Volt	1
VAUX Current	-	-	100	mA	1

Note: 1. When VL IN is utilized, VAUX will match VL.

5.1.3 Power Supply

Mode	Average (mA)	Mode Description
Switched Off		
Terminal Disabled	< 15µA	Terminal disabled (ENABLE SUPPLY = 0)
Cellular Radio Off	0.4	Cellular module powered but switched off via ON_OFF pin (PWRMON=0)
IDLE mode		
AT+CFUN=1	LTE 13 WCDMA 15	Normal mode: full functionality of the module
AT+CFUN=4	11	Disabled TX and RX; module is not registered on the network
AT+CFUN=5	LTE 2 to 6 WCDMA 2	Depends on paging cycle
Operative mode		
LTE Data call	190	Channel BW 5MHz, RB=1, TX=0dBm
LTE Data call	Max power 500	Channel BW 5MHz, RB=1, TX=22dBm
WCDMA Voice	140	WCDMA voice call (TX = 9dBm)
WCDMA HSDPA	Max power 440	WCDMA data call (RMC, TX = 23dBm)

Note: WCDMA only available on LTE910 V7.00

Note: Values are calculated based on power supply efficiency.

5 LTE910CF TECHNICAL SPECIFICATIONS continued

5.1 Electrical Specification continued

5.1.4 I/O Levels

5.1.4.1 1.8v Standard Interface Levels (GPIO 1, 2, 9,10)

Parameter	Min	Typ	Max	Unit	Note
Input Voltage High - Vih	1.5	-	1.9	Volt	
Input Voltage Low - Vil	0	-	0.35	Volt	
Output Voltage High - Voh	1.6	-	1.9	Volt	
Output Voltage Low - Vol	0	-	0.2	Volt	

Typical Current Source/Sink = 100uA/1uA

5.1.4.2 2.85v Standard Interface Levels (UART, GPIO 3-7)

Parameter	Min	Typ	Max	Unit	Note
Input Voltage High - Vih	1.85	-	2.85	Volt	
Input Voltage Low - Vil	0	-	0.99	Volt	
Output Voltage High - Voh	2.45	-	2.85	Volt	
Output Voltage Low - Vol	0	-	0.4	Volt	

Typical Current Source = 100uA/1uA

5.1.4.3 VL IN Selected Interface Levels (UART, GPIO 3-7)

Parameter	Min	Typ	Max	Unit	Note
Input Voltage High - Vih	VL*0.65	-	VL	Volt	
Input Voltage Low - Vil	0	-	VL*0.35	Volt	
Output Voltage High - Voh	VL-0.4	-	VL	Volt	
Output Voltage Low - Vol	0	-	0.4	Volt	

5.1.4.4 ADC Input Levels

Parameter	Min	Typ	Max	Unit	Note
Input Voltage Range	0	-	1.2	Volt	
AD Conversion	-	-	10	Bits	
Input Resistance	1M	-	-	Ohm	
Input Capacitance	-	1	-	pF	

5.1.4.5 Reset Pin Input Levels

Parameter	Min	Typ	Max	Unit	Note
Input Voltage High - Vih	1.5	-	1.9	Volt	
Input Voltage Low - Vil	0	-	0.35	Volt	

It is required that this input be controlled by an Open Collector/Drain Output. Do not use an external pull-up resistor; a pull-up is included internal to the Modem.

5 LTE910CF TECHNICAL SPECIFICATIONS continued

5.1 Electrical Specification continued

5.1.5 LTE Cellular Antenna Specifications:

5.1.5.1 LTE910CF v7.00 (AT&T)

Parameter	Description
Frequency Range	Depending on frequency bands provided by the network operator, the customer should use the most suitable antenna for those frequencies.
Bandwidth	WCDMA 1900 (B2): 140Mhz WCDMA 850 (B5): 70Mhz LTE 1900 (B2): 140Mhz LTE 1700 (B4): 445Mhz LTE 850 (B5): 70Mhz LTE 700 (B17): 42Mhz LTE 700 (B12): 47Mhz
Impedance	50Ω
Input Power	>24 dBm Average power in WCDMA & LTE
VSWR Absolute Max	≤ 10:1
VSWR Recommended	≤ 2:1

5.1.5.2 LTE910CF v6.00 (Verizon)

Parameter	Description
Frequency Range	Depending on frequency bands provided by the network operator, the customer should use the most suitable antenna for those frequencies.
Bandwidth	LTE 1900 (B2): 140 MHz LTE 1700 (B4): 445Mhz LTE 700 (B13): 41Mhz
Impedance	50Ω
Input Power	>24dBm Average Power
VSWR Absolute Max	≤ 10:1
VSWR Recommended	≤ 2:1

5 LTE910CF TECHNICAL SPECIFICATIONS continued

5.1 Electrical Specification continued

5.1.6 USB Transceiver Specifications

Parameter	Comments	Min	Typ	Max	Unit
USB_VBUS					
Supply voltage		4.5	5.0	5.25	Volt
Input levels for low-/full speed					
Receiver threshold (single-end)		0.8	-	2.0	Volt
Differential input sensitivity	D+ - D- , Vin = 0.8V to 2.5V	0.2	-	-	Volt
Differential common-mode range	Includes VDI	0.8	-	2.5	Volt
Output levels for low-/full speed					
Low	RL = 1.5 kΩ to 3.6 V	-	-	0.3	Volt
High	RL – 15 kΩ to GND	2.8	-	3.6	Volt
Output signal crossover voltage		1.3	-	2.0	Volt
Terminations					
Internal pull-up resistor	VTRM to D+, VTRM to D-	1.425	1.5	1.575	kΩ
Internal pull-down resistor	D= to GND, D- to GND	14.3	15	24.8	kΩ
High-Z state output impedance	0 V < VDD < 3.6 V; measured at D+ and D- pins to GND	300	-	-	kΩ
Termination voltage	An internal supply voltage, VTRM	3.0	3.3	3.6	Volt
Driver characteristics – full speed					
Transition time:					
Rise time	CL = 50 to 125 pF	4	-	20	ns
Fall time	CL – 50 to 125 pF	4	-	20	ns
Rise/fall time matching		90	-	111	%
Series output resistance	D+, D-	28	33	44	Ω
Driver characteristics – low speed					
Transition time:					
Rise time	CL = 50 to 600 pF	75	-	300	ns
Fall time	CL – 50 to 600 F	75	-	30	ns
Rise/fall time matching		80	-	125	%

6 Operation

6.1 Powering ON/OFF

6.1.1 Powering ON

Power the Modem ON by pulling the ON_OFF signal (Pin 19) to ground for at least five (5) seconds, then release.

6.1.2 Powering OFF

There are two methods to turn OFF the Modem under normal circumstances:

- Use the AT shutdown command (AT#SHDN)
- Pull ON_OFF signal (Pin 19) to ground for at least three (3) seconds, then release.

In both instances, power can be removed from the modem once the PWRMON signal goes low.

Under abnormal circumstances, the modem can be shut down using the RESET input (pin 20).

6.2. Communicating with the Modem

The default configuration of the modem has AT command ports available on the UART interface and the USB interface.

6.2.1 UART Interface

The UART port operates at the following default parameters:

- Baud Rate: 115.2 kbps
- Bits: 8
- Stop Bits: 1
- Parity: None
- Hardware Handshaking

6.2.2 USB Interface

The USB port instantiates two serial modem connections as AT command ports by default. USB drivers are available from Telit or Janus.

6.3 Testing Communications

- The cellular module should always respond to the attention command with 'OK'. Send:

```
AT<cr>1
```

Note 1. "<cr>" designates a carriage return character.

The module will response with 'OK'.

- Verify the module model. Send:

```
AT+CGMM<cr>
```

The response should be the Telit module model number.

- Verify the firmware version. Send:

```
AT+CGMR<cr>
```

The response will be the Telit module's current firmware.

6 Operation Continued

6.4 Cellular Network Communications

6.4.1 SIM Card

All LTE modems require a SIM card. The LTE910CF v6.00 and v7.00 use a 2FF 'micro' size SIM card.

6.4.2 Data Contexts - setting the APN

6.4.2.1 Checking the Data Contexts

Data connections require that the carrier's Access Point Name (APN) be properly set in the data contexts using the AT+CGDCONT command. In LTE modules, some contexts may be assigned for the carrier's use.

The data contexts can be checked by entering the following command:

```
AT+CGDCONT?<cr>
```

The module will respond with the current data context settings.

*NOTE: A SIM card must be present to read the data contexts.
The default settings for the LTE Cat.M1 modems are as follows:*

LTE910CF v7.00:

```
+CGDCONT: 1,"IPV4V6","","",0,0
```

Context ID 1 is for the user's data connection. It must be set to an appropriate APN.

LTE910CF v6.00:

```
+CGDCONT: 1,"IPV4V6","vzwims","","",0,0  
+CGDCONT: 2,"IPV4V6","vzwadmin","","",0,0  
+CGDCONT: 3,"IPV4V6","vzwinternet","","",0,0  
+CGDCONT: 4,"IPV4V6","vzwapp","","",0,0  
+CGDCONT: 5,"IPV4V6","vzw800","","",0,0  
+CGDCONT: 6,"IPV4V6","vzwclass6","","",0,0
```

Context ID 3 is for the user's data connection; it is set to the default APN for Verizon.

6.4.2.2 Setting the Data Contexts

Make sure you are using an acceptable APN or the device will not register on the network. For example, a general APN for AT&T is "nxtgenphone".

To set a data context with this APN, enter the following:

```
AT+CGDCONT=1,"IPV4V6","nxtgenphone"<cr>
```

and wait for the "OK" response.

NOTE: Carrier services such as a static IP address or VPN may require a specialized APN.

6 Operation Continued

6.4 Cellular Network Communications continued

6.4.3 Signal Strength

Signal strength can be checked as follows. Enter:

```
AT+CSQ<cr>
```

The default response format will contain two numbers:

```
+CSQ: 17,0
```

The first number is the rssi (received signal strength indication) and the second is ber (bit error rate).

The rssi can be interpreted as follows:

10-14 Okay

15-20 Good

20+ Excellent.

Anything below 10 would be considered marginal.

A response of 99 indicates no signal.

6.4.4 Registration

Network registration can be checked as follows. Enter:

```
AT+CEREG?<cr>
```

A response of +CEREG:0,1 or +CEREG: 0,5 indicates the device is registered to the home network or roaming, respectively.

If response is different than this, please refer to the Telit AT command reference document for more information

6.5 Data Communications

The modem incorporates a TCP/IP stack that can be used to directly send data using AT commands. Alternatively, an external host can be used to make a PPP connection.

6.5.1 Data Communications - Using the Internal Stack

To send data using the internal stack, a data context must be activated.

Activate the context as follows:

```
LTE910CF v7.00:
```

```
Enter:
```

```
AT#SGACT=1,1<cr>
```

```
LTE910CF v6.00:
```

```
Enter:
```

```
AT#SGACT=3,1<cr>
```

If successful, the modem will respond with an IP address assigned by the carrier. Data can be sent to a host with a socket dial command. Enter:

```
AT#SD=<connid>,0,80,<IPaddr>
```

where <connid> is the user data context (1 for LTE910 v7.00, 3 for LTE910 v6.00) and <IPaddr> is a text string (in quotes) containing a dotted IP address or a DNS resolvable host name.

The modem will respond with CONNECT and any data entered thereafter will be sent to the connected host.

Enter the escape sequence:

```
+++
```

to suspend the connection.

See the Telit IP Easy User Guide and the Telit AT Commands Guide for more information.

6 Operation continued

6.5 Data Communications continued

6.5.2 PPP Dialing

In a hosted system (e.g. Linux) the host TCP/IP stack can be used. A PPP connection is initiated using the ATD dialing command. Depending on the script or application performing the PPP connection, you may have to change the numeric digit in the PPP AT dialing command that designates the context to use.

The dialing string for the LTE910CF v7.00 would be:

```
ATD*99***1#<cr>
```

Where the '1' digit selects the #1 data context set with the +CDGCONT command.

Similarly the dialing string for the LTE910CF v6.00 would be:

```
ATD*99***3#<cr>
```

Where the '3' digit selects the #3 data context set with the +CDGCONT command.

6.6 SMS

SMS allows you to send a text message (max 160 characters) to a SMS capable unit.

- Set the SMS mode to text. This setting is not persistent; it must be entered every power cycle.

```
AT+CMGF=1<cr>
```

- To enter the receiving subscriber unit phone number and message enter:

```
AT+CMGS="8885551234"<cr>
```

Wait for response ">" then enter message text .

Enter

```
<ctrl-z>
```

to end the message text and send it.

7 Design Considerations

7.1 Minimum Required Module Pin Connects

Pin	Signal	Function	Note
1	VBATT	Main power supply	
2	VBATT	Main power supply	
12	GND	Ground	
25	GND	Ground	
26	GND	Ground	
39	GND	Ground	
49	GND	Ground	
9	TXD	Serial data input (TXD) from DTE	
4	RXD	Serial data output to DTE	
11	RTS	Input for request to send signal (RTS) from DTE	2
19	ON/OFF	Input command for switching power ON or OFF(toggle command)	
20	RESET	Reset input	

Note:

1. If the application uses USB as the main interface to the Modem, this is sufficient to capture any debug or trace data, provided the application can export the diagnostic port externally.
2. RTS must be connected to ground if flow control is not used.

7.2 Debug:

Debug of the Modems in production

To test and debug the mounting of the Modem, we strongly recommend test pads on the host PCB. This will allow verification of the connection between the module itself and the application and to test the performance of the module connecting it with an external computer.

Depending on the customer application, these pads include, but are not limited to the following signals:

- TXD
- RXD
- ON/OFF
- RESET
- GND
- VBATT
- TX_TRACE
- RX_TRACE
- PWRMON
- USB D+
- USB D-
- USB V_BUS

APPENDICES

Approvals

LTE910CF v7.00

FCC: RI7LE910NAV2

IC: 5131A-LE910NAV2

PTCRB, AT&T, Rogers (Canada)

LTE910CF v6.00

FCC: RI7LE910SVV2

Verizon

Antenna Care and Replacement

Do not use the Modem with a damaged antenna.

Buy the antenna from an approved suppliers list. Using unauthorized antennas, modifications, or attachments could damage the Modem and may violate local RF emission regulations or invalidate type approval.

Abbreviations

3GPP	3rd Generation Partnership Project	GSM	Global System Mobile
AC	Alternating Current	IoT	Internet of Things
ADC	Analog To Digital Converter	LED	Light Emitting Diode
APN	Access Point Name	LTE	Long Term Evolution
BER	Bit Error Rate	M2M	Machine To Machine
CD	Carrier Detect	RF	Radio Frequency
CDMA	Code Division Multiple Access	RI	Ring Indicator
CTS	Clear To Send	RSSI	Received Signal Strength Indication
DB	Decibel	RTS	Request To Send
DC	Direct Current	RxD	Received Data
DCE	Data Communications Equipment	SMS	Short Message Service
DSR	Data Set Ready	TTFF	Time To First Fix
DTMF	Dual-tone multi-frequency	TxD	Transmitted Data
DTR	DTE Ready	UICC	Universal Integrated Circuit Card
GNSS	Global Navigation Satellite System	UMTS	Universal Mobile Telecommunications System
GPIO	General Purpose Input Output	USIM	Universal Subscriber Identity Module
HSPA	High Speed Packet Access	VSWR	Voltage Standing Wave Ratio
GPRS	General Packet Radio Service	WCDMA	Wideband Code Division Multiplexing Access

LTE910CF CAT1 Embedded Cellular Modem User Manual

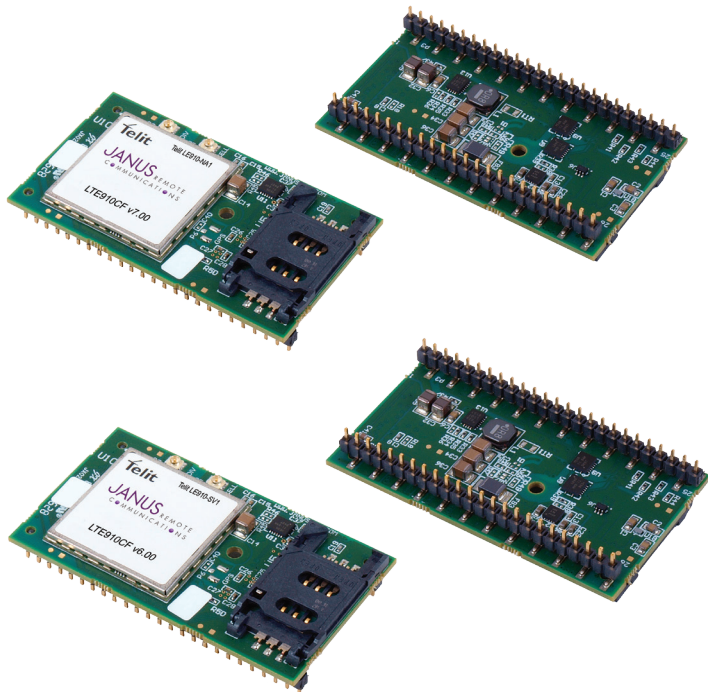

Ordering Information

Ordering Information	Description
LTE910CF v6.00	LTE Cat.1 Plug-In Modem - Verizon
LTE910CF v7.00	LTE Cat.1 Plug-In Modem - AT&T

Revision History

Revision	Revision Date	Note
P00	06/21/17	Preliminary LTE910CF CAT1 Individual Plug-In User Manual
P01	04/04/18	Addition of documentation and block diagram edit

JANUS REMOTE
COMMUNICATIONS

Division of The Connor-Winfield Corporation

2359 Diehl Road • Aurora, IL 60502

Phone: 630.499.2121 • info@janus-rc.com

www.janus-rc.com