

Terminus 400AP Products User Manual – Hardware Guide



JANUS REMOTE
COMMUNICATIONS

Bulletin	JA07-UM-SN3
Revision	A00
Date	30 May 2012

TABLE OF CONTENTS

TABLE OF CONTENTS and DISCLAIMER.....	2
400AP Open Platform General Description	3
Plug-In Terminals	
400AP Peripherals.....	4-8
SDRAM Memory	
NAND Flash Memory	
SD Memory Card	
RS-232 Serial Communications	
RS-232 USART1 Connections	
RS-232 DBGU Connections	
RS-232 Transceiver Connections	
RS-485 Serial Communications	
RS485-USART2 Connections	
USB Host Serial Communications	
USB Device Serial Communications	
Ethernet 10/100 PHY	
Controller Area Network (CAN)	
CAN0 Controller Connections	
CAN0 Transceiver Connections	
CAN1 Controller Connections	
CAN1 Transceiver Connections	
RTC	
Accelerometer	
Cellular Plug-In Terminal	
Plug-In MODEM Connections	8-10
UART_ENABLE Truth Table	
UART SUPPLY Truth Table	
Enable VBUS	
ON_OFF Truth Table	
RESET Truth Table	
PWRMON Truth Table	
SERVICE Truth Table	
GPS_RESET Truth Table	
Monetary Buttons	11
LEDs	11
Red LEDs	
Yellow LEDs	
Green LEDs	
Cellular RF Port - Coming Soon.....	12
GPS RF Port - Coming Soon.....	12
Front Panel - Coming Soon.....	12
Rear Panel - Coming Soon.....	12
20 Pin Header.....	12
Installing SIM Card	
Samtec Part Numbers	14
Electrical Specifications	15-16
Absolute Maximum Ratings	
Recommended Operating Conditions	
I/O Levels (3.3V CMOS)	
I/O Levels (1.8V CMOS)	
I/O Levels (RS-232 Transceiver)	
I/O Levels (RS-485 Transceiver)	
I/O Levels (CAN Transceiver)	
Mechanical Specifications - Coming Soon	17
Ordering Information.....	18
Revision History	18

DISCLAIMER

The information contained in this document is the proprietary information of Connor-Winfield Corporation and its affiliates (Janus Remote Communication). The contents are confidential and any disclosure to persons other than the officers, employees, agents or subcontractors of the owner or licensee of this document, without the prior written consent of Connor-Winfield, is strictly prohibited. Connor-Winfield makes every effort to ensure the quality of the information it makes available. Notwithstanding the foregoing, Connor-Winfield does not make any warranty as to the information contained herein, and does not accept any liability for any injury, loss or damage of any kind incurred by use of or reliance upon the information. Connor-Winfield disclaims any and all responsibility for the application of the devices characterized in this document, and notes that the application of the device must comply with the safety standards of the applicable country, and where applicable, with the relevant wiring rules. Connor-Winfield reserves the right to make modifications, additions and deletions to this document due to typographical errors, inaccurate information, or improvements to programs and/or equipment at any time and without notice. Such changes will, nevertheless be incorporated into new editions of this application note.

All rights reserved 2011 Connor-Winfield Corporation

400AP Open Platform General Description

The 400AP Intelligent Terminus provides a complete wireless communication device with integrated ARM9™ processor, expanded memory and cellular communication protocols to fit any application. The AMTEL ARM9™ processor has a large support community available to reference while developing applications. Additionally, Janus has hardware/software partners waiting to assist users in quickly getting your product to market. The Terminus 400AP allows users the flexibility to choose OS and if users are looking for embedded Linux OS, we can show them how to set up Linux toolchain to quickly compile a Linux Kernel and Filesystem so users are up and running in hours.

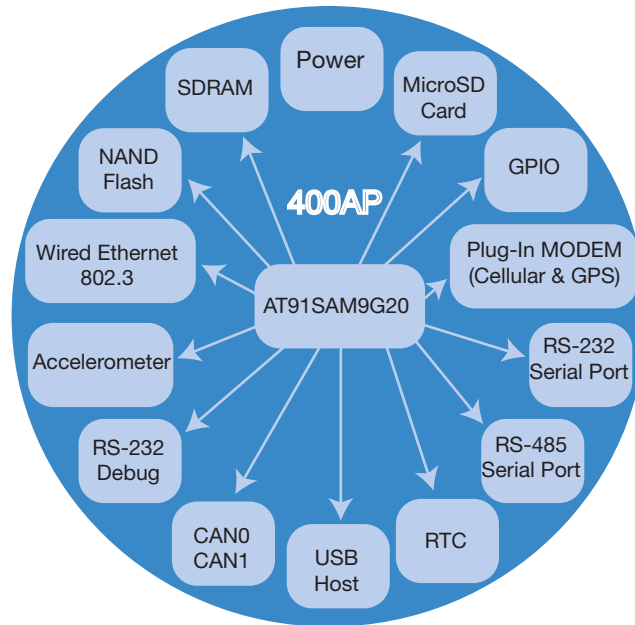

Plug-In Terminals:

Cellular communication protocols for the Terminus 400AP are powered by Terminus Plug-In terminals. Plug-In Terminus offer easy integration and interchangeability of communication protocols between GSM/GPRS, CDMA, HSPA and more by combining full M2M functionality with the flexibility of a standard “plug-in” DIP design. These terminals share the same mechanical footprint and offer users the ability to configure their applications for communications via any cellular protocol. By using these modules to power the cellular technology of the 400AP, users can easily change cellular technology without having to change platforms. The 400AP provides one platform that supports current cellular technology with the future in mind.

400AP Peripherals:

The 400AP is loosely based on the Atmel AT91SAM9G20 reference design. The following section will describe the connections of memory and peripherals as they pertain to the 400AP platform.

SDRAM Memory:

The 400AP includes a single chip of 64MB SDRAM and is connected to the External Bus Interface (EBI) of the 9G20 processor via a 16-bit data bus. For a complete description of the EBI and static memory controller refer to the Atmel AT91SAM9G20 User Manual.

For a complete technical description of the SDRAM memory please refer to the Micron Data Sheet.

Micron Part Number: MT48H32M16LFB4-75 IT:C

NAND Flash Memory:

A single chip of 128MB bootable NAND flash is connected to the EBI of the 9G20 processor via an 8-bit data bus. For a complete description of the EBI and NAND flash support refer to the Atmel AT91SAM9G20 User Manual.

For a complete technical description of the NAND flash memory please refer to the Micron Data Sheet.

Micron Part Number: MT29F1G08ABDDAH4:D

SD Memory Card:

A micro SD memory card socket is connected to the MultiMedia Card Interface (MCI) of the 9G20 processor via Slot A. Slot A can be used to boot an application from or be used to store application data. The MCI is compliant with the SD Memory Card Specification V1.0

400AP Peripherals continued:

RS-232 Serial Communications:

Two RS-232 serial ports are available on the 400AP. The 9G20 debug serial port is exposed externally via a DB9 connector on the front panel of the 400AP. This port can be used as a Universal Synchronous Asynchronous Receiver Transceiver (USART) or as the serial interface to the Debug Unit (DBGU) of the 9G20 processor. The debug USART is implemented with RX and TX signaling. The second RS-232 serial port is externally exposed via the 20-pin locking connector on the rear panel of the 400AP and is connected to USART1 of the 9G20 processor. USART1 is capable of using RTS/CTS hardware flow control. For a complete description of the DBGU and USART functionality refer to the Atmel AT91SAM9G20 User Manual.

Both ports use the same RS-232 transceiver chip and can be simultaneously disabled by use of the FORCEON and NFORCEOFF control inputs. For a complete description of this functionality please refer to the Texas Instrument Data Sheet.

Texas Instrument Part Number: MAX3238

RS-232 USART1 Connections:

AT91SAM9G20		400AP – Locking Header 2x10		
Pin Name	Function	Pin	Name	Function
PB6	TXD1	12	RS232-TX	Serial Data Output
PB7	RXD1	14	RS232-RX	Serial Data Input
PB28	RTS1	16	RS232-RTS	Ready To Send Output
PB29	CTS1	18	RS232-CTS	Clear To Send Input

RS-232 DBGU Connections:

AT91SAM9G20		400AP – DB9		
Pin Name	Function	Pin	Name	Function
PB15	DTXD	2	RS232-DTX	Serial Data Output
PB14	DRXD	3	RS232-DRX	Serial Data Input

RS-232 Transceiver Connections:

AT91SAM9G20		MAX3238		
Pin Name	Function	Pin	Name	Function
PA23	GPIO	13	FORCEON	Force On Input (Pulled-High)
PA24	GPIO	14	NFORCEOFF	Force Off Input (Pulled-High)

J1708 / RS-485 Serial Communications:

A single J1708 RS-485 serial port is available on the 400AP. The RS-485 serial port is externally exposed via the 20-pin locking connector on the rear panel of the 400AP. The serial port is connected to USART2 of the 9G20 processor. For a complete description of the USART and RS-485 functionality refer to the Atmel AT91SAM9G20 User Manual.

For a complete description of the RS-485 transceiver please refer to the Maxim Data Sheet.

Maxim Part Number: MAX13430E.

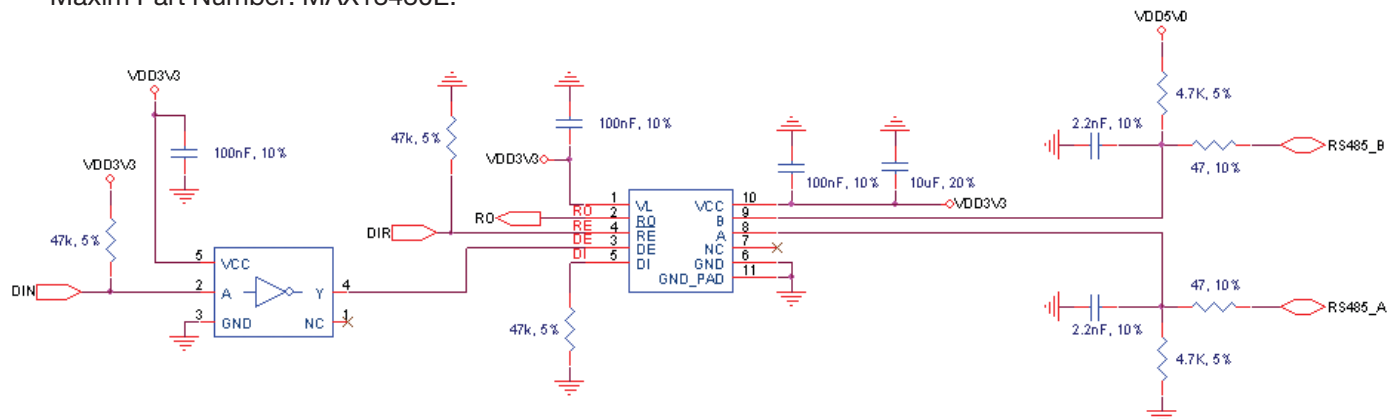

Figure 1 - Transceiver Configuration

400AP Peripherals continued:

J1708 / RS-485 Serial Communications continued

RS-485 Connections:

AT91SAM9G20			MAX13430E	
Pin Name	Function	Pin	Name	Function
PB8	TXD2 (Inverted)	3	DE	Driver Output Enable
PB9	RXD2	2	RO	Receiver Output

MAX13430E		400AP – Locking Header 2x10	
Pin	Name	Pin	Function
8	RS485A Serial Data I/O A	6	Serial Data I/O A
9	RS485B Serial Data I/O B	8	Serial Data I/O B

USB Host Serial Communications:

There are two USB host ports on the 400AP. Channel B - USB Host Port (UHP) controls the Janus Remote Communications Plug-In cellular terminal. Channel A - USB Host Port (UHP) is externally exposed on the front panel of the 400AP. For a complete description of the USB and UHP functionality refer to the Atmel AT91SAM9G20 User Manual.

USB Device Serial Communications:

There is a single USB device port externally exposed on the front panel of the 400AP. The USB Device Port (UDP) is compliant with the Universal Serial Bus (USB) V2.0 full-speed device specification. For a complete description of the USB and UDP functionality refer to the Atmel AT91SAM9G20 User Manual.

Ethernet 10/100 PHY:

A physical layer transceiver for 100BASE-TX and 10BASE-T operations is available on the 400AP. The physical layer fully complies with IEEE802.3/ IEEE802.3U 10BASE-T /100BASE-TX standards. The physical layer is connected to the Ethernet 10/100 MAC of the 9G20 processor via an RMII interface. For a complete description of the Ethernet 10/100 MAC refer to the Atmel AT91SAM9G20 User Manual.

For a complete technical description of the physical layer chip please refer to the Davicom Data Sheet.

Davicom Part Number: DM9161BIEP

400AP Peripherals continued:

Controller Area Network (CAN):

Two stand-alone Controller Area Network (CAN) controllers/transceivers are available on the 400AP. The CAN controllers comply with version 2.0B of the Controller Area Network specification. The CAN controllers are connected via the SPI interface of the 9G20 processor. For a complete description of the SPI interface refer to the Atmel AT91SAM9G20 User Manual.

For a complete technical description of the CAN controller and transceiver chip please refer to the NXP Data Sheets.

Microchip Part Number: MCP2515

NXP Part Number: TJF1051

CAN0 Controller Connections:

AT91SAM9G20		MCP2515		
Pin Name	Function	Pin	Name	Function
NRST	Reset	19	RESET	Reset
PA3	SPI0 – NPCS0	18	CS	Chip Select
PA0	SPI0 – MISO	17	SO	Serial Data Out
PA1	SPI0 – MOSI	16	SI	Serial Data In
PA2	SPI0 – SPCK	14	SCK	Serial Clock
PB20	GPIO	13	INT	Interrupt
PB21	GPIO	12	RX0BF	RXB0 Interrupt
PB1	GPIO	11	RX1BF	RXB1 Interrupt

CAN0 Transceiver Connections:

TJF1051			400AP – Locking Header 2x10		
Pin	Name	Function	Pin	Name	Function
7	CANH	CAN High-Level I/O	7	CANH0	CAN High-Level I/O
6	CANL	CAN Low-Level I/O	9	CANL0	CAN Low-Level I/O
TJF1051			AT91SAM9G20		
8	S	Silent Mode Enable	PB13	GPIO	

CAN1 Controller Connections:

AT91SAM9G20		MCP2515		
Pin Name	Function	Pin	Name	Function
NRST	Reset	19	RESET	Reset
PC16	SPI0 – NPCS2	18	CS	Chip Select
PA0	SPI0 – MISO	17	SO	Serial Data Out
PA1	SPI0 – MOSI	16	SI	Serial Data In
PA2	SPI0 – SPCK	14	SCK	Serial Clock
PB2	GPIO	13	INT	Interrupt
PB3	GPIO	12	RX0BF	RXB0 Interrupt
PB16	GPIO	11	RX1BF	RXB1 Interrupt

CAN1 Transceiver Connections:

TJF1051			400AP – Locking Header 2x10		
Pin	Name	Function	Pin	Name	Function
7	CANH	CAN High-Level I/O	13	CANH1	CAN High-Level I/O
6	CANL	CAN Low-Level I/O	15	CANL1	CAN Low-Level I/O
TJF1051			AT91SAM9G20		
8	S	Silent Mode Enable	PB13	GPIO	

400AP Peripherals continued:

Real Time Clock (RTC):

A battery backed up RTC is available on the 400AP. The RTC has a built-in power-on reset controller that controls the NRST input of the AT91SAM9G20 processor. The RTC is connected via the SPI interface of the 9G20 processor. For a complete description of the SPI interface refer to the Atmel AT91SAM9G20 User Manual.

For a complete technical description of the RTC please refer to the ST data sheet.

ST Part Number: M41T94

AT91SAM9G20		M41T94		
Pin Name	Function	Pin	Name	Function
NRST	Reset Input	3	RST	Power-on Reset OD output
PC17	SPI0 – NPCS3	15	CS	Chip Select
PA0	SPI0 – MISO	9	SO	Serial Data Out
PA1	SPI0 – MOSI	12	SI	Serial Data In
PA2	SPI0 – SPCK	10	SCK	Serial Clock
PC18	GPIO	14	IRQ	Interrupt Output
		5	MR	400AP External Reset Button

RTC Backup Battery:

A CR1220 primary Lithium coin cell is supplied with the 400AP. The battery socket has been protected from reverse battery installation. During reverse battery installation the RTC will not be able to maintain time when power is removed.

Accelerometer:

A three axis digital accelerometer is available on the 400AP. The SPI / I2C interface of the accelerometer has been connected via 9G20 GPIO.

For a complete technical description of the accelerometer please refer to the Bosch data sheet.

ST Part Number: BMA222

AT91SAM9G20		BMA222		
Pin Name	Function	Pin	Name	Function
PC19	GPIO	2	SDA/SDI	SPI Data Input, I2C Data
PC20	GPIO	12	SCL/SCK	Serial Clock Input
PC21	GPIO	1	SA0/SDO	SPI Data Output, I2C A0
PC22	GPIO	10	CS	Chip Select
PC23	GPIO	11	PS	Protocol Select
PC24	GPIO	6	INT2	Interrupt Output 2
PC25	GPIO	1	INT1	Interrupt Output 1

Cellular Plug-In Terminal:

A socket for a Janus Remote Communication Plug-In terminal is available on the 400AP. There is a GSM/GPRS, CDMA/1xRTT, and HSPA version of the Plug-In terminal available. All required I/O to control the Plug-In terminal including USB; USART and GPIO's are described below. For a complete technical description of the Plug-In Terminus, please refer to the Janus Remote Communications User Guide.

Janus Remote Communications Part Numbers: GSM865CF, CDMA864CF and HSPA910CF

Plug-In MODEM Connections:

AT91SAM9G20		Plug-In MODEM			Note
Pin Name	Function	Pin	Name	Function	
PC15	GPIO	3	ENABLE SUPPLY	Plug-In Enable Input	
PC8	GPIO	19	ON_OFF	ON OFF Toggle Input	
PC9	GPIO	20	RESET	Cellular Reset Input	
PB31	GPIO	18	PWRMON	Power Monitor Output	
PC12	GPIO	17	SERVICE	Service Input	
PC10	GPIO	35	GPS_RESET	MS20 GPS Reset Input	
PB11	RXD3	34	GPS_TX	MS20 NMEA TXD Output	
PB10	TXD3	33	GPS_RX	MS20 NMEA RXD Input	
PA30	RXD4	13	TRACE_TX	Trace Serial Port – TXD Output	1
PA31	TXD4	14	TRACE_RX	Trace Serial Port – RXD Input	1
PB4	TXD0	9	TXD	DCE Serial Port – TXD Input	1
PB5	RXD0	4	RXD	DCE Serial Port – RXD Output	1
PB26	RTS0	11	RTS	DCE Serial Port – RTS Input	1
PB27	CTS0	6	CTS	DCE Serial Port – CTS Output	1
PB22	DSR0	5	DSR	DCE Serial Port – DSR Output	1
PB24	DTR0	10	DTR	DCE Serial Port – DTR Input	1
PB23	DCD0	8	DCD	DCE Serial Port – DCD Output	1
PB25	RI0	7	RING	DCE Serial Port – RING Output	1
HDPB	USB Data +	28	USB_D+	USB D+	
HDMB	USB Data -	27	USB_D-	USB D-	

Notes:

1) Digital I/O is level converted to match I/O levels between the AT91SAM9G20 and the Plug-In MODEM. Level converted outputs from the AT91SAM9G20 can be set High-Z by use of UART_ENABLE input.

UART_ENABLE Truth Table:

UART_ENABLE (PB30)	Function
0	AT91SAM9G20 digital outputs driving into Plug-In terminal are enabled. This state should be entered when the Plug-In terminal is powered on.
1	AT91SAM9G20 digital outputs driving into Plug-In terminal are set to High-Z. This state should be entered when the Plug-In terminal is powered off.

ENABLE SUPPLY Truth Table:

ENABLE SUPPLY (PC15)	Function
0	Plug-In terminal power supply is enabled and supplying power to the Plug-In terminal.
1	Plug-In terminal power supply is disabled.

ENABLE VBUS (PC3)

ENABLE VBUS (PC3)	Function
0	Plug-In terminal VBUS input is set to ground.
1	Plug-In terminal VBUS input is set to 5Vdc.

Plug-In MODEM Connections continued:

ON_OFF Truth Table:

ON_OFF (PC8)	Function
0	Run state. Input should remain in this state after the Plug-In terminal has been turned On or Off.
1	Toggle state. Input should remain in this state for a specified amount of time in order to turn On or Off the Plug-In terminal. Hold time to turn Plug-In terminal On: > 1s Hold time to turn Plug-In terminal Off: > 2s

RESET Truth Table:

RESET (PC9)	Function
0	Run state. Input should remain in this state when Plug-In terminal is operational.
1	Reset State. Hold time to reset Plug-In terminal: > 200ms

PWRMON Truth Table:

PWRMON (PB31)	Function
0	Plug-In terminal is in an On State.
1	Plug-In terminal is in an Off State.

SERVICE Truth Table:

SERVICE (PC12)	Function
0	SERVICE state is disabled.
1	SERVICE state is enabled; GSM400AP models can have GSM radio firmware uploaded via TRACE serial port.

Note: Applies to GSM400AP models only

GPS_RESET Truth Table:

GPS_RESET (PC10)	Function
0	Run state. Input should remain in this state when MS20 GPS receiver is operational.
1	MS20 GPS Receiver Reset State. Hold time to reset MS20 GPS receiver: > 1ms

Note: Applies to GSM400AP V1.00 model only

Plug-In MODEM Connections continued:

On power up the Plug-In terminal is in an off state. To turn on the Plug-In terminal the following steps must be followed.

1. Enable Plug-In terminal power supply.
PC15 = Logic Low
2. Clear Cellular Reset.
PC9 = Logic Low
3. High-Z all digital outputs driving into the Plug-In terminal.
PB30 = Logic High
4. For GSM400AP models disable Service mode.
PC12 = Logic Low
5. For GSM400AP V1.00 models clear MS20 GPS receiver reset.
PC10 = Logic Low
6. Set ON_OFF signal
PC8 = Logic High
7. Wait at least 3 seconds
8. Clear ON_OFF signal
PC8 = Logic Low
9. Read PWRMON input to determine if the Plug-In MODEM is on.
PB31 = = Logic Low
10. Enable USART.
PB30 = Logic Low

At this time the Plug-In terminal is on and AT commands can be sent via USART0. CDMA and HSPA 400AP models can also use the AT command virtual serial port exposed via the USB port.

To turn off the Plug-In terminal the following steps must be followed.

1. High-Z all digital outputs driving into the Plug-In terminal.
PB30 = Logic High
2. Set ON_OFF signal
PC8 = Logic High
3. Wait at least 3 second
4. Clear ON_OFF signal
PC8 = Logic Low
5. Read PWRMON input to determine if the Plug-In terminal is on.
PB31 = = Logic High

At this point the Plug-In terminal is turned off.

Momentary Buttons:

Reset Button: The Reset button is connected to the reset controller of the 400AP. When pressed and released the 400AP is reset.

Mode Button: The Mode button is used to place the 400AP into different operational modes during boot. After boot, the mode button is available to the Application via 9G20 GPIO PB18.

Mode	400AP Operation State	Mode Entry Conditions
Normal Run Mode	400AP powered. After reset is released, the red light will illuminate. Application executes from first bootable media found. Note: If no bootable media is found the 9G20 will boot into SAM-BA mode. The green LED will not illuminate in this case.	<ol style="list-style-type: none"> 1. Apply power to 400AP or depress Reset Button 2. Mode Button is not pressed
SAM-BA Mode	400AP powered. 9G20 boots into SAM-BA mode and green LED illuminates. Note: Using this method to enter SAM-BA mode is supported when using the factory-supplied bootloader that evaluates the Mode button during boot. If NAND Flash has been erased, this functionality will not exist. The 400AP application note Uploading Files into Flash explains how to write the bootloader to flash..	<ol style="list-style-type: none"> 1. Press Mode button 2. Apply power to 400AP or depress Reset Button 3. Depress Mode after Green LED illuminates
Application Interrupt Mode	400AP is in Normal Run Mode. 9G20 GPIO PB18 is set logic high when Mode button is pressed. Note: The 400AP response to the mode button is defined by the application that was executed during boot.	<ol style="list-style-type: none"> 1. 400AP is in Normal Run Mode 2. Press Mode button

LED's:

Red LED: The Red LED is connected to GPIO PB12 of the 9G20 processor. This LED is on by default unless the application defines its state.

Red LED State	400AP Operation Mode
Permanently On - during boot	400AP is powered
Application defined after boot	Booted into application which controls LED state

Yellow LED:The yellow LED indicates the Plug-in Terminal operation status.

Yellow LED State	400AP Operation State
Permanently Off	Cellular radio is off
Permanently On	A call is active
Fast Blinking (0.5 sec on / 0.5 sec off)	Net search / not registered / turning off
Slow Blinking (0.3 sec on / 2.7 sec off)	Registered, full service

Green LED: The green LED is connected to GPIO PB17 of the 9G20 processor. This LED is off by default unless the application defines its state.

Green LED State	400AP Operation State
Permanently Off – during boot	Booting into application
Permanently On – during boot	Entered SAMBA Mode
Application defined – after boot	Booted into application which controls LED state

Cellular RF Port:

SMA - FEMALE

Pin	Description
Center Pin	Cellular Signal
Outer Conductor	SIGNAL Ground

For Cellular RF Port details, view the [Plug-In Terminus Manual](#) as reference.

GPS RF Port:

MCX - FEMALE

Pin	Description
Center Pin	GPS Signal, 3.7 Vdc nominal supplied from Terminus to power active antenna.
Outer Conductor	Signal ground

Note: GPS Antenna Interface only available by option, otherwise not populated.

For GPS RF Port details, view [Plug-In Terminus User Manual](#) as reference

Front Panel:



Rear Panel:



20 Pin Header

PIN	Description	Direction	LEVEL
1	9G20 GPIO (PC0)	IN / BI-DIR	Analog / 3.3v CMOS
2	9G20 GPIO (PA5)	BI-DIR	3.3v CMOS
3	9G20 GPIO (PC1)	IN / BI-DIR	Analog / 3.3v CMOS
4	9G20 GPIO (PB19)	BI-DIR	3.3v CMOS
5	GND	N/A	N/A
6	RS485_A	BI-DIR	RS-485
7	CAN0_HI	BI-DIR	CAN
8	RS485_B	BI-DIR	RS-485
9	CAN0_LO	BI-DIR	CAN
10	GND	N/A	N/A
11	GND	N/A	N/A
12	RS232 TX	OUTPUT	RS-232
13	CAN1_HI	BI-DIR	CAN
14	RS232 RX	INPUT	RS-232
15	CAN1_LO	BI-DIR	CAN
16	RS232 RTS	OUTPUT	RS-232
17	Enable	IN	12.0v (Active High)
18	RS232 CTS	INPUT	RS-232
19	VIN	IN	12.0v
20	GND	N/A	N/A

Samtac Part Numbers:

Housing: IPD1-10-D-K

Contacts: CC79L-2024-01-L

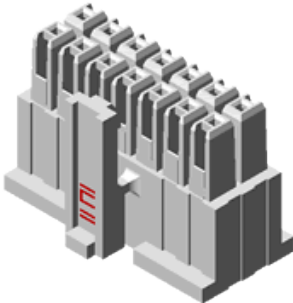

Janus Store Part Number:

XT- 478-G



XT-479-G

Installing SIM Card into the GSM/HSPA 400AP

Step 1. To access the 400AP board, remove the four TX-10 screws from the ruggedized aluminum enclosure. These screws are located on the back panel of the 400AP where the DB9 and lock header are located.



continued...

Installing SIM Card into the GSM/ HSPA 400AP continued

Step 2. Slide out the back panel which will include the 400AP board.

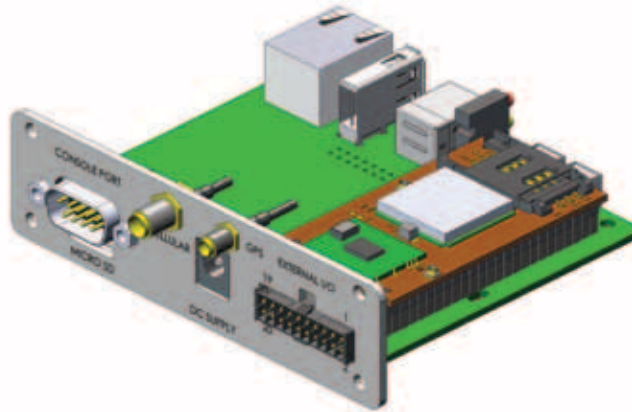

Step 3. Locate the SIM Card slot on top of the Terminus Plug-In board.

Step 4. To insert the SIM card in the SIM card slot, slide the top of the cover back to unlock. Insert the SIM card in the cover slot and close. Slide back to original position to lock in place.

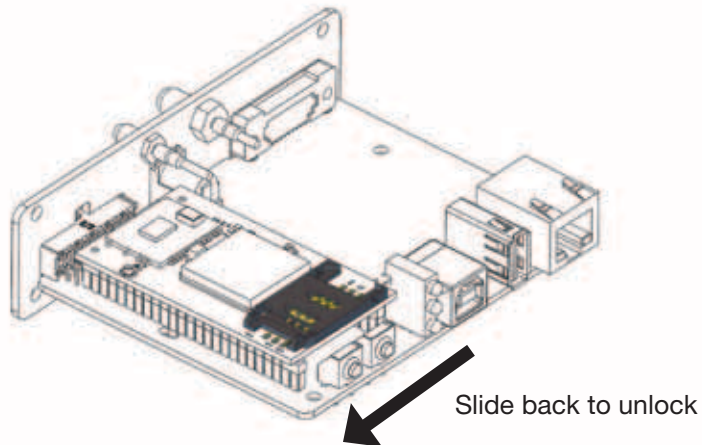

Step 5. Slide the back panel and 400AP board into the aluminum enclosure. Replace the four TX-10 screws and tighten them back on to enclosure.



Electrical Specifications:

Absolute Maximum Ratings:

Parameter	Minimum	Nominal	Maximum	Unit	Note
Storage Temperature	-40	-	85	°C	1
Supply (Supply & Enable Input)	-36	-	36	Volt	1,2
VIN (Digital Inputs 3.3V CMOS)	-0.3	-	3.6	Volt	1
VIN (Digital Inputs 1.8V CMOS)	-0.3	-	2.1	Volt	1
VIN (RS-232 Inputs)	-25	-	25	Volt	1
VIN (RS-485 Inputs)	-8	-	13	Volt	1
VIN (CAN Inputs)	-42	-	42	Volt	1
VIN (USB Inputs)	-0.3	-	3.6	Volt	1

Notes:

- 1) Operation of the device at these or any other conditions beyond those listed under Recommended Operating Conditions is not implied. Exposure to Absolute Maximum Rating conditions for extended periods of time may affect device reliability.
- 2) The supply inputs are protected from reverse voltage and transients beyond the Recommended Operating Conditions. If transients persist the supply will be latched in a disable state. Once disabled the supply will need to be cycled off and on to reset.

Recommended Operating Conditions:

Parameter	Minimum	Nominal	Maximum	Unit	Note
Operational Temperature:					
GSM400AP V1.1	-20	-	65		
GSM400AP V2.0	-40	-	85	°C	
CDMA400AP	-30	-	80		
HSPA400AP	-30	-	80		
Supply (Supply & Enable Input)	7	-	26	Volt	
Peak Supply Power	-	-	12.5	Watts	1
Average Supply Current	-	-	TBD	Amp	2

Notes:

- 1) Peak Supply Power specification is stated as the minimum amount of power the external power supply must supply during the TX burst of the embedded cellular radio. Please refer to the Plug-In User Manual for power supply characteristics of the embedded Plug-In Module embedded in the 400AP terminal. Plug-In User Manual can be downloaded at <http://www.janus-rc.com/terminuscf.html>
- 2) Average Supply Current specification is stated as the maximum average current the 400AP terminal can draw while maintaining junction temperatures within the internal power supply IC's specifications. It is the applications responsibility to maintain operation within this limit to maintain reliable operation over the life of this terminal product.

I/O Levels (3.3V CMOS)

Parameter	Minimum	Nominal	Maximum	Unit	Note
Input Voltage Low - Vil	-0.3	-	0.8	Volt	
Input Voltage High - Vih	2	-	3.6	Volt	
Output Voltage Low – Vol	-	0.4	Volt	1	
Output Voltage High – Voh	2.9	-	-	Volt	1
Output Current - Io	-	-	8	mA	
Pull-up Resistance - RPULLUP	40	75	190	kohm	

Notes:

- 1) Test conditions: Max Io.

I/O Levels (RS-232 Transceiver)

Please refer to the Texas Instruments data sheet for a complete listing of specifications for the RS-232 transceiver used in the 400AP terminal.

Texas Instrument Part Number: MAX3238

Electrical Specifications continued:

I/O Levels (RS-485 Transceiver)

Please refer to the Microchip data sheet for a complete listing of specifications for the RS-485 transceiver used in the 400AP terminal.

Maxim Part Number: MAX13430

I/O Levels (CAN Transceiver)

Please refer to the NXP data sheet for a complete listing of specifications for the CAN transceiver used in the 400AP terminal.

NXP Part Number: TJF1051 T/3

Mechanical Specifications:

TERMINUS-400AP WITHOUT SIDE MOUNTING BRACKETS

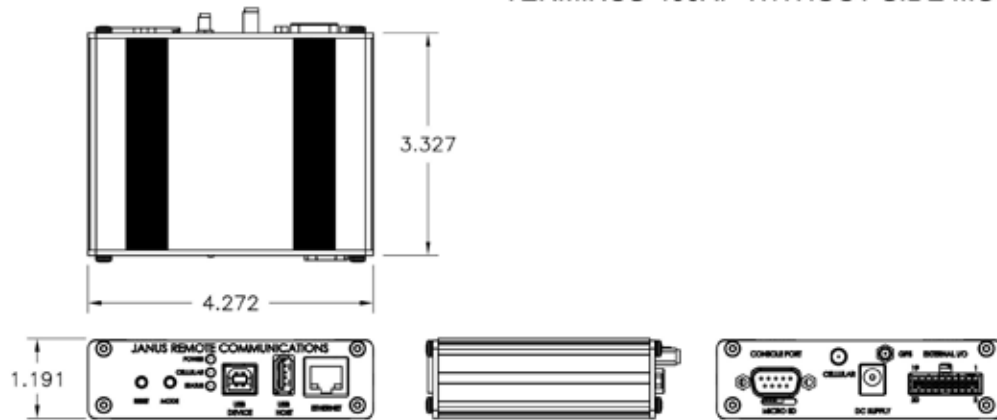

TERMINUS-400AP WITH SIDE MOUNTING BRACKETS

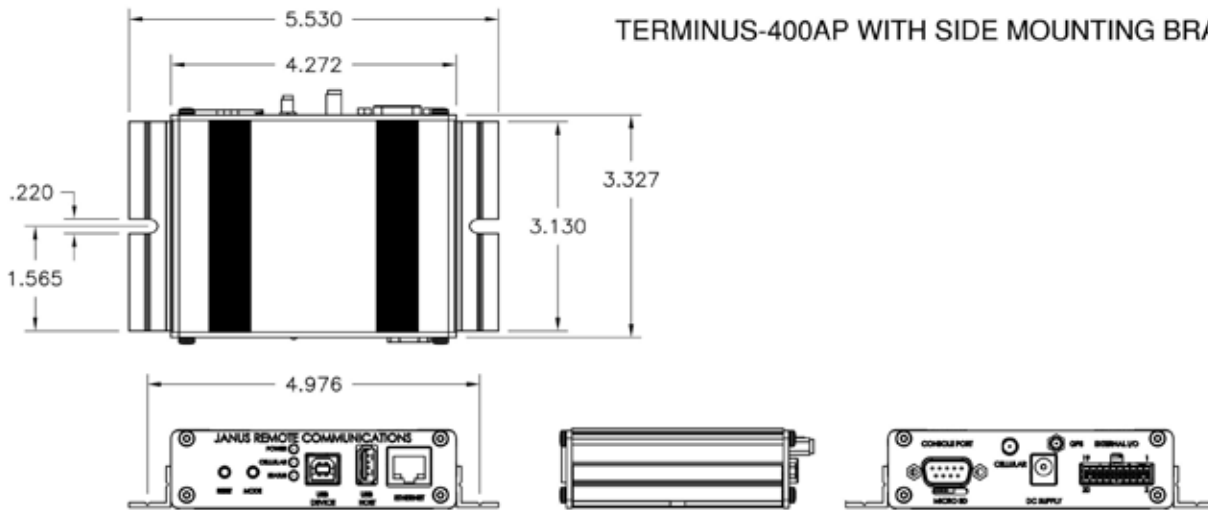

Terminus 400AP Products User Manual – Hardware Guide



Ordering Information	Description
GSM400AP v1.00	GSM with GPS
GSM400AP v2.00	GSM without GPS
CDMA400AP v2.00	CMDA – Sprint Certified
CDMA400AP v3.00	CDMA – Verizon Certification Pending
HSPA400AP v1.00	HSPA

Revision History

Revision	Revision Date	Note
A00	05/30/12	Advanced Release - User Manual



Division of The Connor-Winfield Corporation
2111 Comprehensive Drive • Aurora, Illinois 60505
630.499.2121 • Fax: 630.851.5040

www.janus-rc.com

Janus Remote Communications Europe
Bay 143
Shannon Industrial Estate
Shannon, Co. Clare, Ireland
Phone: +353 61 475 666