

CDMA910CF Plug-In Embedded Cellular Modem User Manual

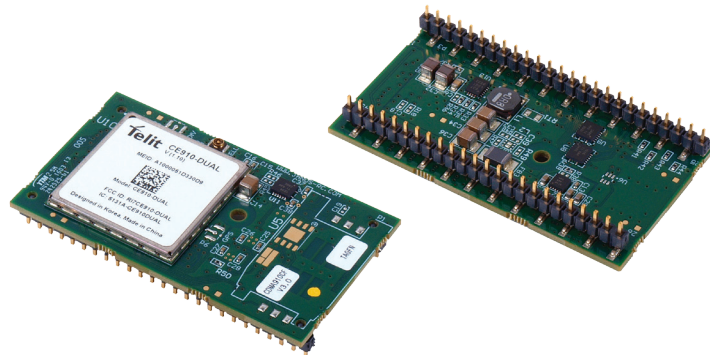

JANUS REMOTE
COMMUNICATIONS

Bulletin	JA03-UM-CDMA
Revision	P02
Date	12 April 2017

TABLE OF CONTENTS

TABLE OF CONTENTS and DISCLAIMER.....	2
1 APPLICABILITY TABLE.....	3
2 REFERENCES	3
2.1 Telit Document List.....	3
3 OVERVIEW.....	4
3.1 Introduction	4
3.2 Preview	4
3.3 CDMA Features	5
3.4 CDMA Block Diagram	5
4 INTERFACES.....	6-14
4.1 Serial Interface.....	6-7
4.2 Power Supply	7
4.3 Audio Interface	8
4.4 CF Plug-In Pin-Out	9
4.5 VRTC Details.....	10
4.6 GPIO Details	10-13
4.7 User LED.....	13
4.8 LED Status Indicators	13
4.9 RF Interface	14
4.10 Header Interface Mounting Options.....	14
4.11 Screw Mounting.....	14
5 CDMA910CF TECHNICAL SPECIFICATIONS	15-23
5.1 Electrical Specifications.....	15-17
5.2 CDMA Mechanical Specifications	18
5.3 Setting Up a Terminal Emulator for use with the CDMA910CF modem	19-20
6 DESIGN CONSIDERATIONS	21
6.1 Minimum Required Module Pin Connects	21
6.2 Debug.....	21
APPENDICES	22
Approvals.....	22
Safety	22
Antenna Care and Replacement.....	22
Abbreviations.....	22
Ordering Information	23
Revision History.....	23

DISCLAIMER

The information contained in this document is the proprietary information of Connor-Winfield Corporation and its affiliates (Janus Remote Communication). The contents are confidential and any disclosure to persons other than the officers, employees, agents or subcontractors of the owner or licensee of this document, without the prior written consent of Connor-Winfield, is strictly prohibited. Connor-Winfield makes every effort to ensure the quality of the information it makes available. Notwithstanding the foregoing, Connor-Winfield does not make any warranty as to the information contained herein, and does not accept any liability for any injury, loss or damage of any kind incurred by use of or reliance upon the information. Connor-Winfield disclaims any and all responsibility for the application of the devices characterized in this document, and notes that the application of the device must comply with the safety standards of the applicable country, and where applicable, with the relevant wiring rules. Connor-Winfield reserves the right to make modifications, additions and deletions to this document due to typographical errors, inaccurate information, or improvements to programs and/or equipment at any time and without notice. Such changes will, nevertheless be incorporated into new editions of this application note.

All rights reserved 2014 Connor-Winfield Corporation

1 APPLICABILITY TABLE

Product	Part Number
CDMA910CF – Sprint	v2.00
CDMA910CF – Verizon Certified	v3.00
CDMA910CF – Aeris	v4.00

2 REFERENCES

2.1 Telit Document List

CDMA910CF

Our terminal uses Telit module CE910.

Please refer to Telit's website at www.telit.com for the latest information on the CDMA CE910 Module.

Telit_CE910_Hardware_User_Guide

Telit_CE910_Software_User_Guide

Telit_CE910_AT_Commands_Reference_Guide

3 OVERVIEW

3.1 Introduction

The user manual for the Common Footprint (CF) Plug-in modem is intended to illustrate how users can integrate the unit and implement the features needed for their application.

3.2 Preview

The CF Plug-In Modems are self-contained, multi-band, globally capable, and network certified, M2M communication devices designed to provide a comprehensive solution to application problems for our M2M customers. They utilize the proven technology of Telit's certified modules, for their core communications engines.

3.2.1 Functional Description

GPS Functionality

- CDMA910CF does not include GPS

Cellular

- CDMA910CF: 1xRTT

USB

- CDMA910CF: FS USB 2.0 Device (12Mb/s)

Physical Dimensions

- Length and width of all CF Plug-In devices are equal
- Heights of different devices will vary

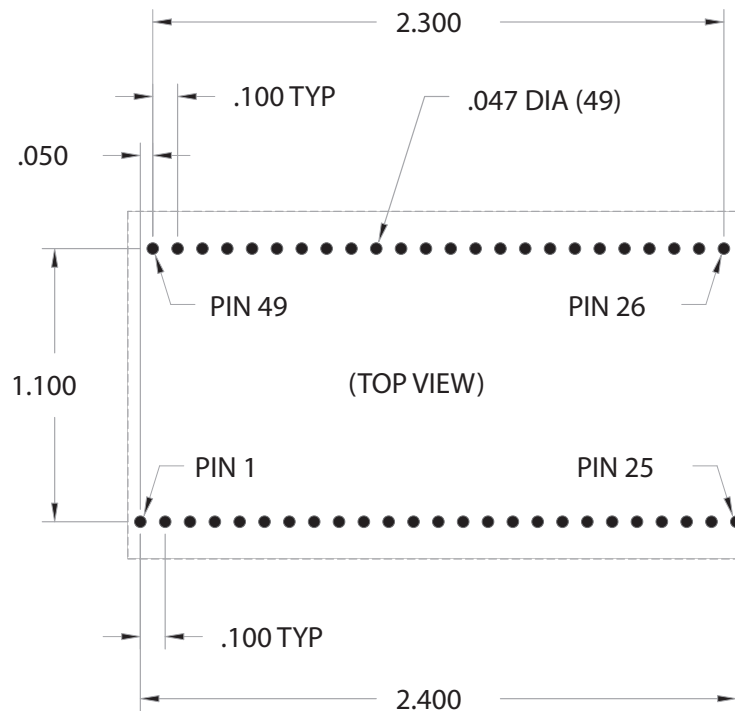

3 OVERVIEW continued

3.3 Features

Dual-Band CDMA

1xRTT 800, 1900

Control via AT commands according to 3GPP TS27.005, 27.007 and Telit customized AT commands

UDP / TCP / FTP / SMTP Stack

SMS Access

Full voice via PCM

OTA provisioning, device management, and firmware upgrades

Output power

Class 3 (24.5dBm) @ BC0 1xRTT 800 / 1900

Class 2 (24.5dBm) @ BC1 1xRTT 800 / 1900

Sensitivity

-108 dBm @ BC0 1xRTT 800 / 1900

-107dBm @ BC1 1xRTT 800 / 1900

Data

DL: Up to 153.6kbps, UL: Up to 153.6kbps

Operational Temperature Range: -40°C to 85°C

Internal Switching Regulator:

Input Voltage Range: 4.75 to 5.25Vdc (5V nominal)

Supply disable via terminal input pin

Cellular access available via Murata GSC miniature RF connector

3.4 Block Diagram

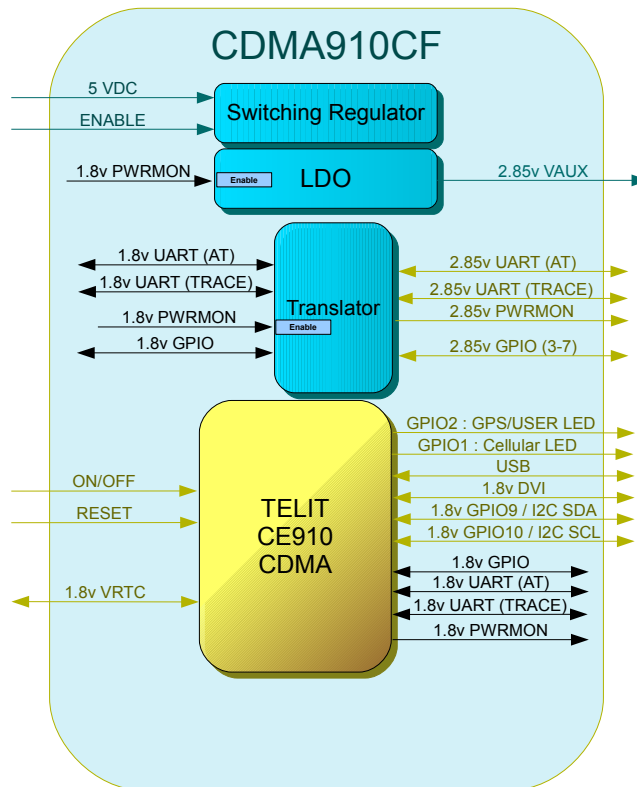

Figure 1 CDMA910CF Block Diagram

4 INTERFACES

4.1 Serial Interface

4.1.1 UART Serial Port

The serial interface is a CMOS level UART. Default Communications settings for this port are as follows:

- Baud Rate: 115.2 kbps
- Bits: 8
- Stop Bits: 1
- Parity: None
- Hardware Handshaking: Yes

The CDMA910CF does not support autobaud, and must be changed via the AT+IPR command. It is defaulted to 115200 bps

Note: If you are not using Hardware Handshaking, please note that RTS must be connected to GROUND for proper communications where flow control is unused.

4.1.1.1 UART Level Translation

The electrical limits for the UART are listed in the individual modem sections. Please be aware of these limits, as operating outside of them may damage the unit. If the limits must be exceeded, level translation can be used.

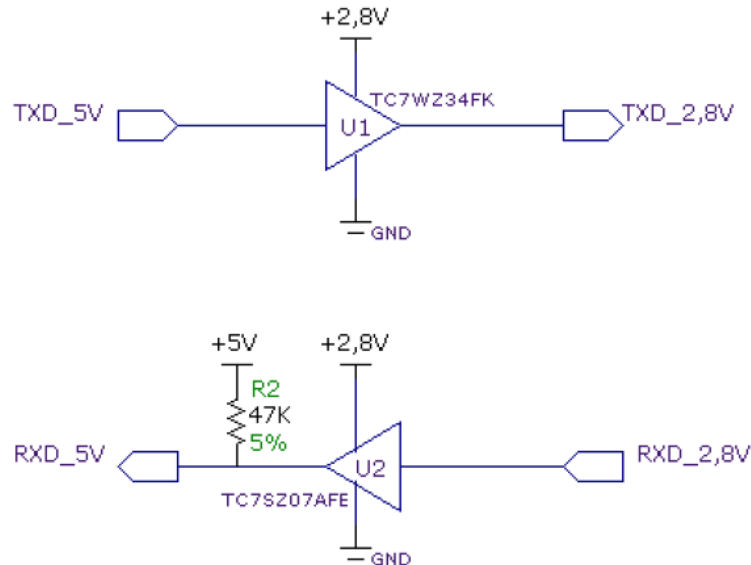

Figure 2 UART Level Translation Example

An example of basic translation for RXD/TXD only is found below.

Although an external source for the level translation can be used, VAUX can be used as the reference instead. However, some CF Plug-In Modems require AT commands to control VAUX, PWRMON may be used as an enable to an external reference. Do not use PWRMON directly as the reference.

4.1.2 USB Port

The CF Plug-In modems that are USB ready include an integrated universal serial bus (USB) transceiver, compliant with USB 2.0 specifications. High data rates for the USB enabled modems are only available over the USB interface, as the UART has a maximum baud rate of <1Mbps. In order for proper power-up of the CF Plug-In Modems, the USB_VBUS line MUST be disconnected until the unit is otherwise fully powered and on. If the USB_VBUS line is attached and powered before the main power is brought up and the module turned on, power sequencing issues may occur.

Note: You must implement the USB interface in order to locally update radio firmware.

4 Interfaces continued

4.1.2 USB Port continued

4.1.2.1 USB Connection Diagram

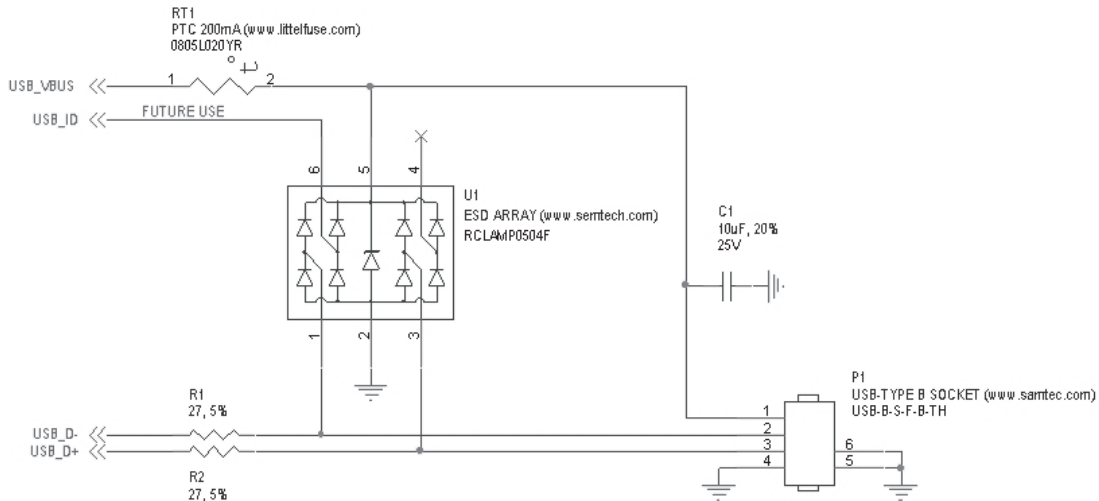

Figure 3 USB Connection Diagram

4.1.2.2 USB VBUS Switch

USB_VBUS is input, when VBUS_ENABLE is HIGH the 5v signal will be passed to TERMINUS_VBUS, turning the USB ON.

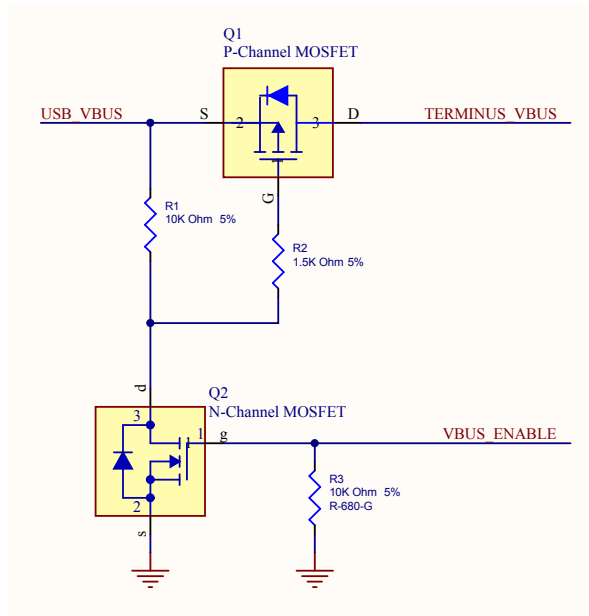

Figure 4 USB VBUS Switch Example

4 Interfaces continued

4.2 Power Supply

The module's power supply accepts input voltages from 4.75Vdc to 5.25Vdc and requires a nominal current sourcing capacity of 5W (maximum 10W).

Power Supply

A good understanding of the load transients is required in order to meet the power requirements of a cellular radio. Power supply design, thermal management and layout are outside the scope of this document. Please refer to power supply manufacturers for product documentation and design application notes.

Cellular Load Transients

Cellular radios use a mix of modulation schemes including, but not limited to, TDMA and CDMA. In GSM/GPRS systems the transmission and reception of data is achieved via Time Division Multiple Access (TDMA). TDMA transmission is made up of RF bursts that cause 2A current pulses at the supply input of the cellular radio. These current pulses occur at a frequency of 216 Hz and can persist for 1.2 to 2.4ms.

On Board Regulator

This CF Plug-In module is designed with a switching regulator to power the cellular radio. The regulator can receive an input voltage of 3.7 to 5.25VDC to maintain regulation, but can also accept down to 3.3VDC, in which regulation is bypassed. This is useful for battery operated applications. Note that an input voltage below 4.75VDC is outside of rated specifications and thus not supported by Janus.

Note: The regulator input is capable of withstanding 6VDC Maximum. This is outside the recommended operating voltage of the CF Plug-In modules but is helpful to know when designing input transient circuitry.

CF Plug-In Module Input Supply Requirements

The current values are given in average units due to the pulsed nature of the transmission scheme. It is recommended that your supply source the full peak current value of the transmission pulse in order to maintain proper cellular operation. The use of bulk output capacitors on your supply allows for a less powerful supply.

4.3 Audio Interface

4.3.1 CDMA910CF

The xxx910CF modules use a DVI audio interface which will not work with the analog audio interface on some of the other CF Plug-In modems. The CDMA910CF supports PCM, master and slave modes, and can use a CODEC to convert the interface to analog. Below is a block diagram based on DVI and the MAX9867 CODEC with GPIO 9 and 10 being used for I2C control of the CODEC.

Please refer to the referenced DVI Application Notes for full information and example schematics utilizing the MAX9867 Audio CODEC.

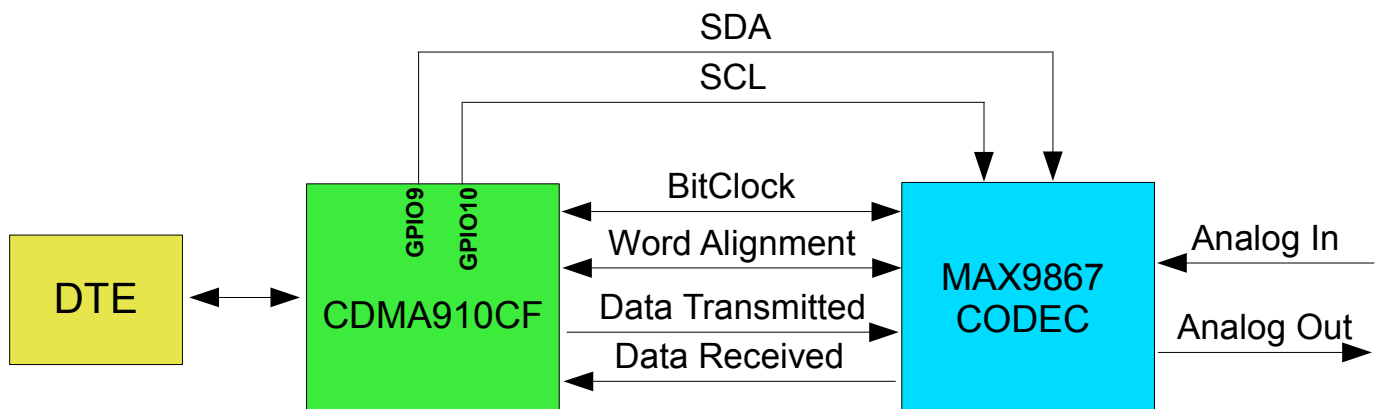

Figure 5 DVI Block Diagram

4 Interfaces continued

4.4 CF Plug-In Pin-Out

PIN	PIN NAME	DESCRIPTION	STANDARD I/O SIGNAL	POWER-ON STATE	PULL TYPE	NOTE
1	SUPPLY	Positive Supply Input	Power	N/A	N/A	
2	SUPPLY	Positive Supply Input	Power	N/A	N/A	
3	ENABLE SUPPLY	Enable/Disable Supply	Input	N/A	PULL-UP to Vin: 681k	1
4	RXD	UART - Transmit Line	Output	N/A	N/A	6
5	DSR	UART - Data Set Ready	Output	N/A	N/A	6
6	CTS	UART - Clear to Send	Output	N/A	N/A	6
7	RING	UART - Ring Indicator	Output	N/A	N/A	6
8	DCD	UART - Data Carrier Detect	Output	N/A	N/A	6
9	TXD	UART - Receive Line	Input	N/A	N/A	6
10	DTR	UART - Data Terminal Ready	Input	N/A	N/A	6
11	RTS	UART - Request to Send	Input	N/A	N/A	4
12	GROUND	Supply Reference	Power	N/A	N/A	
13	TRACE_TX	Debug UART - Transmit Line	Output	N/A	N/A	6
14	TRACE_RX	Debug UART - Receive Line	Input	N/A	N/A	6
15	USER	USER LED	Output	N/A	N/A	6
16	CELLULAR LED	Cellular Status	Output	N/A	N/A	6
17	SERVICE	Unused	N/A	N/A	N/A	5
18	PWRMON	Power Monitor Output	Output	N/A	PULL-DOWN:1M	6
19	ON_OFF	Toggle Cellular Radio On Off State	Input	N/A	PULL-UP to VTRC: 47k	1
20	RESET	Reset Cellular Radio	Input	N/A	PULL-UP: 47k	1
21	DVI WAO	DVI Word Alignment	WCLK	N/A	N/A	6
22	DVI RX	DVI Received Data	SDIN	N/A	N/A	6
23	DVI TX	DVI Transmitted Data	SDOUT	N/A	N/A	6
24	DVI CLK	DVI Data Clock	BCLK	N/A	N/A	6
25	GROUND	Supply Reference	Power	N/A	N/A	
26	GROUND	Supply Reference	Power	N/A	N/A	
27	USB_D-	USB Differential Data (-)	CMOS Bi-Direction	N/A	N/A	9
28	USB_D+	USB Differential Data (+)	CMOS Bi-Direction	N/A	N/A	9
29	USB_VBUS	USB Supply	Power	N/A	N/A	9
30	USB_ID	Future Use	Analog Input	N/A	N/A	2,3
31	I2C_SDA	I2C Data	CMOS Bi-Direction	INPUT	N/A	
32	I2C_SCL	I2C Clock	CMOS Bi-Direction	INPUT	N/A	
33	GPS_RX	Unused	N/A	N/A	N/A	5
34	GPS_TX	Unused	N/A	N/A	N/A	5
35	GPS_RESET	Unused	N/A	N/A	PN/A	5
36	GPIO_7	General Purpose I/O	Bi-Direction	INPUT	N/A	6
37	GPIO_6	General Purpose I/O	Bi-Direction	INPUT	N/A	6
38	GPIO_5	General Purpose I/O	Bi-Direction	INPUT	N/A	6
39	GROUND	Supply Reference	Power	N/A	N/A	
40	GPIO_4	General Purpose I/O	Bi-Direction	INPUT	N/A	6
41	GPIO_3	General Purpose I/O	Bi-Direction	INPUT	N/A	6
42	GPIO_2	Unused	N/A	N/A	N/A	5
43	GPIO_1	Unused	N/A	N/A	N/A	5
44	DAC	Unused	N/A	N/A	N/A	5
45	ADC2	Unused	N/A	N/A	N/A	5
46	ADC1	Analog to Digital Converter	Analog Input	N/A	N/A	6
47	VRTC	Unused	N/A	N/A	N/A	
48	VAUX	Reference Voltage	Analog Output	N/A	N/A	
49	GROUND	Supply Reference	Power	N/A	N/A	

Notes:

1. It is required that this input be controlled by an Open Collector/Drain Output. Do not use an external pull-up resistor; a pull-up is included internal to the module.
2. Not currently implemented
3. USB On The Go: Analog input used to sense whether a peripheral device is connected and determine the peripheral type; a host or a peripheral.
4. RTS must be connected to GROUND if flow control is not used.
5. Not used CDMA910CF
6. Refer to the electrical specifications for I/O levels.

4 Interfaces continued

4.5 VRTC Details

The VRTC pin brings out the real time clock supply, which is separate from the rest of the part. This allows only the RTC to be ON when all other parts of the device are OFF. A backup capacitor can be added to this pin to increase RTC autonomy while powering the device from a battery. The CDMA910CF cannot take advantage of the VRTC functionality.

No devices should be powered from this pin.

Equations:

$$C = 3600 * [(Btime * IRTC)/(VRTC - VRTCmin)]$$

$$Btime = [C * (VRTC - VRTCmin)/(IRTC * 3600)]$$

Where:

VRTC – The Starting voltage of the capacitor (Volt)

VRTCmin – The minimum voltage acceptable for the RTC circuit. (Volt)

IRTC (Ampere) – The current consumption of the RTC circuitry when VBATT = 0

Btime - Backup Time (Hours)

C = Capacitor value (Farads)

Values for the GSM865CF/CDMA864CF

VRTC = 2.05v Nominal

VRTC minimum input voltage to function = 1.1v

IRTC = 10uA nominal

Values for the HSPA910CF

VRTC = 1.8v Nominal

VRTC minimum input voltage to function = 1.1v

IRTC = 2uA nominal

Values for the EVDO910CF

VRTC = 3.1v Nominal

VRTC minimum input voltage to function = 2.0v

IRTC = 1.1uA nominal

Values for the CDMA910CF

VRTC = N/A

VRTC minimum input voltage to function = N/A

IRTC = N/A

For Example, using the HSPA910CF numbers:

Btime = 96 hours (4 days)

C = 1.0F

4.6 GPIO Details

GPIO are configurable as input, output, and special function. Configuration is controlled by the customer specific application via AT commands. The following table describes GPIO configuration options.

GPIO	Configuration	Alternate Function	ON_OFF State
1	Input / Output	Status LED	pull-up
2	Input / Output	User LED	pull-up
3	Input / Output	N/A	pull-down
4	Input / Output	N/A	pull-down
5	Input / Output	N/A	pull-down
6	Input / Output	N/A	pull-up
7	Input / Output	N/A	pull-down

4 Interfaces continued

4.6 GPIO Details continued

4.6.1 Using a GPIO Pad as INPUT

The GPIO pads, when used as inputs, can be connected to a digital output of another device and report its status, provided this device has interface levels compatible with the Voltage levels of the GPIO of the module.

4.6.2 Using a GPIO Pad as OUTPUT

The GPIO pads, when used as outputs, can drive CMOS digital devices or compatible hardware. When set as outputs, the pads have a push-pull output.

4.6.3 Analog to Digital Converter

ADC	Description
1	Analog to digital converter input

4.6.4 I2C

The I2C interface is an alternate function of the modem's GPIO, for the CDMA910CF, those two signals are designated for GPIO 9 (SDA) and GPIO 10 (SCL) and are 1.8V logic level to match the DVI interface for easy usage with a codec. The signals are not pulled up on the CF Plug-In module and must be pulled up externally as they may also be used as spare GPIO.

Please reference the Telit AT Command Guide for details on the I2C commands.

4.6.5 ENABLE Pin

Input Logic State	Description
High-Z	Active state
0	Shutdown

Notes:

1. It is required that this input be controlled by an open collector/drain output. Do not use an external pull-up resistor, a pull-up to VIN is included internal to the modem.
2. The ENABLE pin is offered as a means to turn off the on-board regulator for when a full power cycle is needed or an ultra low power state is required. The ENABLE pin is not intended to be used as a means of turning the modem off. use the ON/OFF pin to turn the modem on or off.
3. Shut down state must be held for 10ms before returning to active state.
4. The regulator is operational 2mS after active state is entered.

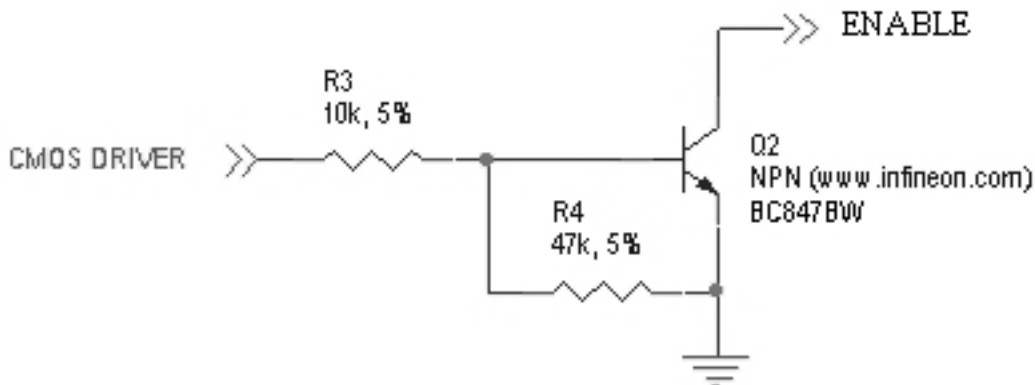

Figure 6 Enable Pin

4 Interfaces continued

4.6 GPIO Details continued

4.6.8 RESET Pin

Input Logic State	Description
High-Z	Active state
0	Reset state

Notes:

1. It is required that this input be controlled by an open collector/drain output. Do not use an external pull-up resistor, a pull-up is included internal to the modem.
2. The RESET pin is offered as a means to reset the modem when and if the modem becomes unresponsive. The RESET pin is not intended to be used as a means of turning the modem off. Use the ON/OFF pin to turn the modem on or off.
3. RESET state must be held for at least 200ms before returning to active state.

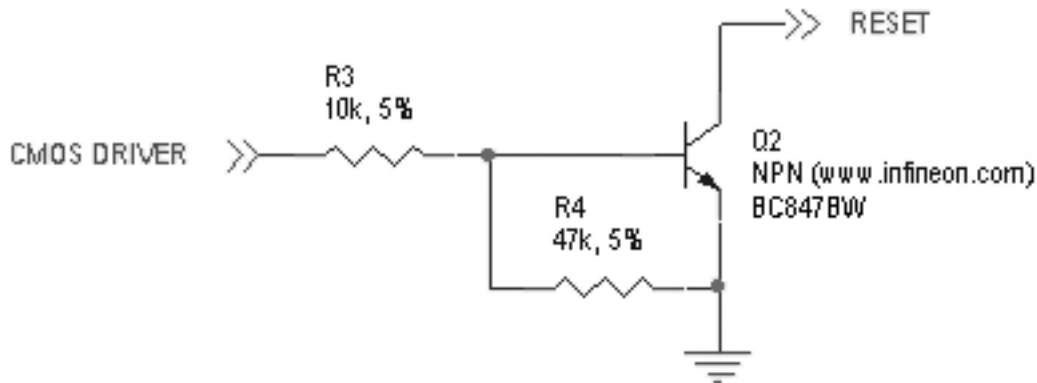

Figure 7 Reset Pin Diagram

4.6.9 ON/OFF Pin

Input Logic State	Description
High-Z	Modem turned ON or OFF after input returns to this state.
0	Toggle modem ON or OFF

Notes:

1. It is required that this input be controlled by an open collector/drain output. Do not use an external pull-up resistor, a pull-up is included internal to the modem.
2. The ON/OFF pin is offered as a means to power-on and power-down the modem. When the modem powers-down it informs the cell tower that it is powering down and will not be communicating with the tower any more. This is considered a controlled power-down.
3. After toggling the power state of the modem, wait until PWRMON indicates chosen state before toggling the power state again.
4. To turn ON the plug-in module, the ON_OFF input must be tied low for 3 second then released.
5. To turn OFF the plug-in module, the ON_OFF input must be tied low for 2 seconds then released.
6. Optionally the modem may be powered-down with the use of AT commands.
7. It is required to stop driving terminal inputs high when turning ON the CF Plug-In module by floating or bringing them low. If this is not done, power sequencing issues may occur.

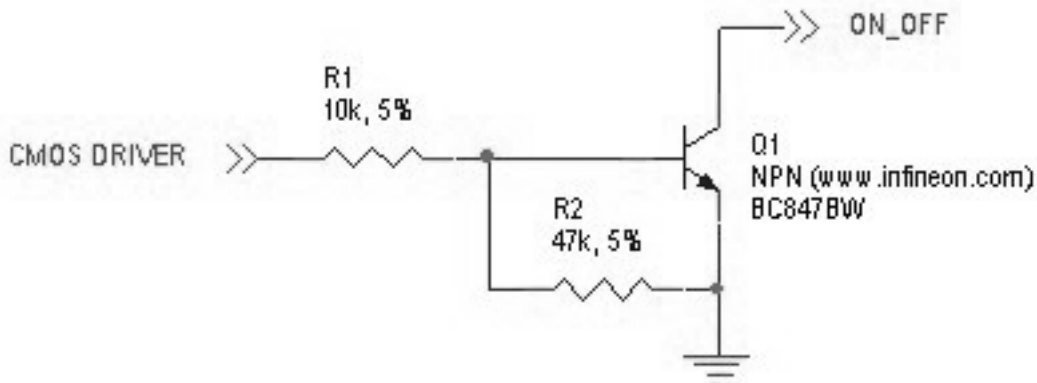

Figure 8 On / Off Pin Diagram

4 Interfaces continued

4.6 GPIO Details continued

4.6.10 PWRMON Pin

Output Logic State	Description
0	modem powered-down
1	modem powered-on

Notes:

1. Used in conjunction with ON/OFF pin to control power-on and power-down state.
2. During a power down, it is required to stop driving terminal inputs high by floating or bringing them low. If this is not done, the PWRMON output will not transition low. On the GSM865CF and CDMA910CF, this will cause the VAUX output to remain active.

4.6.11 VAUX

A regulator power supply output that is provided in order to supply small devices from the module itself.

When PWRMON is HIGH, VAUX will be ON. When PWRMON is LOW, VAUX will be OFF.

4.7 User LED

This module has GPIO2 connected to the User LED pin of the modem. The user application can use this to control an LED or act as an additional GPIO. See figure 10 for recommended connection of an LED.

4.8 LED Status Indicators

The LED Status output is used to drive an external LED to give feedback on the current operation. See figure 10 for recommended connection of an LED. For the CDMA910CF, this is an alternate function of GPIO1 and must be set via the AT#GPIO command. The status is defined below.

4.8.1 Cellular LED Status (CDMA910CF)

LED Status	Device Status
Permanently Off	Cellular radio is off
Permanently On	On/Searching
Slow Blinking (0.3 sec on / 2.7 sec off)	Registered
Fast Blinking (0.5 sec on / 0.5 sec off)	Shutting down

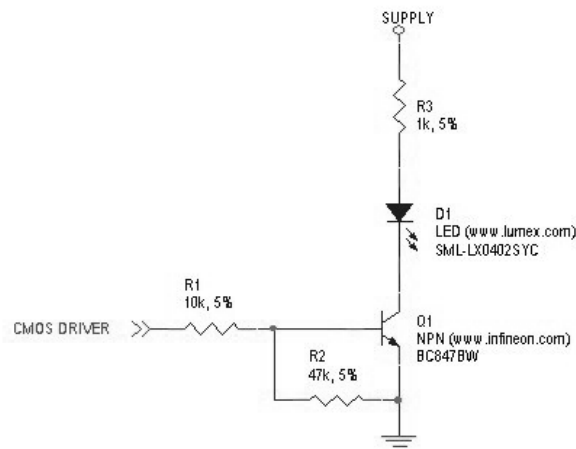

Figure 9 LED Indicators Diagram

4 Interfaces continued

4.9 RF Interface

There is one RF interface on the CDMA910CF, a cellular connector. The specifications and requirements for this is as follows:

Note: You must access the RF connections via the SMT GSC connections if they do not include a GSC to SMA connector.

These signals are NOT electrically connected elsewhere on the board.

4.9.1 CDMA910CF Antenna Interface

Type: Murata GSC - MALE (Murata Part #MM9329-2700RA1)

Pin	Description
Center Pin	RF signal
Outer Conductor	Signal ground

4.10 Header Interface Mounting Options

The CF Plug-In Modules' header pin length has been chosen to allow for direct solder mount to a PCB of standard thickness. If the user wishes to socket the CF Plug-In Module, they may do so as well by using the below part numbers for reference:

Samtec 25 pin header: TSM-125-04-L-SV-A

Samtec 24 pin header: TSM-124-04-L-SV-A

Mating Samtec 25 pin connector: SLW-125-01-G-S

Mating Samtec 24 pin connector: SLW-124-01-G-S

Please note there are no Samtec SMT single row mating connectors. The only mating connector available is the above listed THT version.

4.11 Screw Mounting

The CDMA910CF allows for the use of a #4 machine screw to help keep a socketed module in place where environmental variables may cause problems otherwise. If the user wishes to have a stand-off underneath the module to help alleviate possible stress from mounting hardware, below are the Janus part numbers and associated drawings for an available solution.

4-40 Hex Female Stand-off: MC-0356-G

4-40 3/16" Pan Head Phillips Machine Screw: MC-0357-G

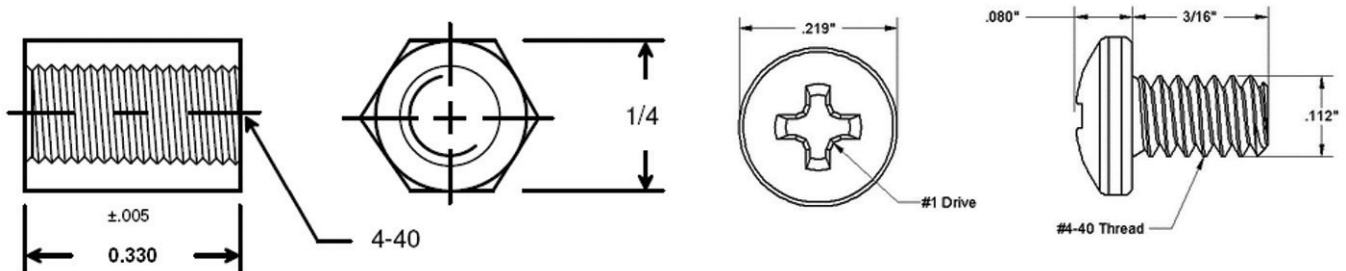

Figure 10 Screw Diagram

5 CDMA910CF TECHNICAL SPECIFICATIONS

5.1 Electrical Specification

5.1.1 Absolute Maximum Ratings

Parameter	Min	Typ	Max	Unit	Note
VIN (DIGITAL INPUTS 2.85V CMOS)	-0.5	-	3.35	Volt	
VIN (DIGITAL INPUTS 1.8V CMOS)	-0.3	-	3.1	Volt	
Storage Temperature	-40	-	85	°C	
Supply (+) referenced to Supply (-)	0	-	6	Volt	

Operation of the device at these or any other conditions beyond those listed under Recommended Operating Conditions is not implied. Exposure to Absolute Maximum Rating conditions for extended periods of time may affect device reliability.

5.1.2 Recommended Operating Conditions

Parameter	Min	Typ	Max	Unit	Note
Temperature	-30	-	80	°C	
Supply (+) referenced to Supply (-)	4.75	5.0	5.25	Volt	
VAUX Output	-	2.85	-	Volt	
VAUX Current	-	-	100	mA	

5.1.3 Power Supply

Mode	Average (mA)	Mode Description
POWERED DOWN		
Terminal Disabled	≤ 15μA	Terminal disabled (ENABLE SUPPLY = 0)
Cellular Radio Off (MON=0)	0.4	Cellular module powered but switched off via ON_OFF pin (PWR-MON=0)
IDLE MODE		
Mode	Average (mA)	Mode Description
AT+CFUN=1	26	Idle, no call in progress. Full functionality of the module
AT+CFUN=4	24	Disabled TX and RX; module is not registered on the network
AT+CFUN=5	3	CFUN=5 full functionality with power saving; Module registered on the network can receive incoming call and SMS
CDMA		
Voice	TBD	Voice channel
Data	655	Data channel

* Data taken with USB disconnected.

5 CDMA910CF TECHNICAL SPECIFICATIONS continued

5.1 Electrical Specification continued

5.1.4 I/O Levels

5.1.4.1 1.8v Standard Interface Levels (DVI, I2C, GPS LED)

Parameter	Min	Typ	Max	Unit	Note
Input Voltage High - Vih	1.5	-	1.9	Volt	
Input Voltage Low - Vil	0	-	0.35	Volt	
Output Voltage High - Voh	1.6	-	1.9	Volt	
Output Voltage Low - Vol	0	-	0.2	Volt	

Typical Current Source/Sink = 100uA/1uA

5.1.4.2 2.85v Standard Interface Levels (UART, GPIO)

Parameter	Min	Typ	Max	Unit	Note
Input Voltage High - Vih	1.85	-	2.85	Volt	
Input Voltage Low - Vil	0	-	0.99	Volt	
Output Voltage High - Voh	2.45	-	2.85	Volt	
Output Voltage Low - Vol	0	-	0.4	Volt	

Typical Current Source = 100uA/1uA

5.1.4.3 Cellular LED Output Levels

Parameter	Min	Typ	Max	Unit	Note
Output Voltage High - Voh	1.6	-	1.9	Volt	
Output Voltage Low - Vol	0	-	0.2	Volt	

Typical Current Source = 100uA

5.1.4.4 ADC Input Levels

Parameter	Min	Typ	Max	Unit	Note
Input Voltage Range	0	-	1.2	Volt	
AD Conversion	-	-	10	Bits	
Input Resistance	1M	-	-	Ohm	
Input Capacitance	-	1	-	pF	

5.1.4.5 Reset Pin Input Levels

Parameter	Min	Typ	Max	Unit	Note
Input Voltage High - Vih	1.5	-	1.9	Volt	
Input Voltage Low - Vil	0	-	0.35	Volt	

It is required that this input be controlled by an Open Collector/Drain Output. Do not use an external pull-up resistor, a pull-up is included internal to the modem.

5 CDMA910CF TECHNICAL SPECIFICATIONS continued

5.1 Electrical Specification continued

5.1.5 CDMA Cellular Antenna Specifications:

5.1.5.1 Antenna Specifications

Parameter	Description
Frequency Range	Depending on frequency bands provided by the network operator, the customer should use the most suitable antenna for those frequencies.
Bandwidth	70MHz in CDMA BC0 140 MHz in CDMA BC1
Gain	Gain < 5.12dBi in CDMA BC0 Gain < 6.12dBi in CDMA BC1
Impedance	50Ω
Input Power	24.5dBm Average Power in CDMA
VSWR Absolute Max	≤ 5:1
VSWR Recommended	≤ 2:1

5.1.6 USB Transceiver Specifications

Parameter	Comments	Min	Typ	Max	Unit
USB_VBUS					
Supply voltage		4.5	5.0	5.25	Volt
Supply current				25	mA
Input levels for low-/full speed					
Receiver threshold (single-end)		0.8	-	2.0	Volt
Differential input sensitivity	D+ - D- , Vin = 0.8V to 2.5V	0.2	-	-	Volt
Differential common-mode range	Includes VDI	0.8	-	2.5	Volt
Output levels for low-/full speed					
Low	RL = 1.5 kΩ to 3.6 V	-	-	0.3	Volt
High	RL – 15 kΩ to GND	2.8	-	3.6	Volt
Output signal crossover voltage		1.3	-	2.0	Volt
Terminations					
Internal pull-up resistor	VTRM to D+, VTRM to D-	1.425	1.5	1.575	kΩ
Internal pull-down resistor	D= to GND, D- to GND	14.3	15	24.8	kΩ
High-Z state output impedance	0 V < VDD < 3.6 V; measured at D+ and D- pins to GND	300	-	-	kΩ
Termination voltage	An internal supply voltage, VTRM	3.0	3.3	3.6	Volt
Driver characteristics – full speed					
Transition time:					
Rise time	CL = 50 to 125 pF	4	-	20	ns
Fall time	CL – 50 to 125 pF	4	-	20	ns
Rise/fall time matching		90	-	111	%
Series output resistance	D+, D-	28	33	44	Ω
Driver characteristics – low speed					
Transition time:					
Rise time	CL = 50 to 600 pF	75	-	300	ns
Fall time	CL – 50 to 600 F	75	-	30	ns
Rise/fall time matching		80	-	125	%

5 CDMA910CF TECHNICAL SPECIFICATIONS continued

5.2 Mechanical Specification

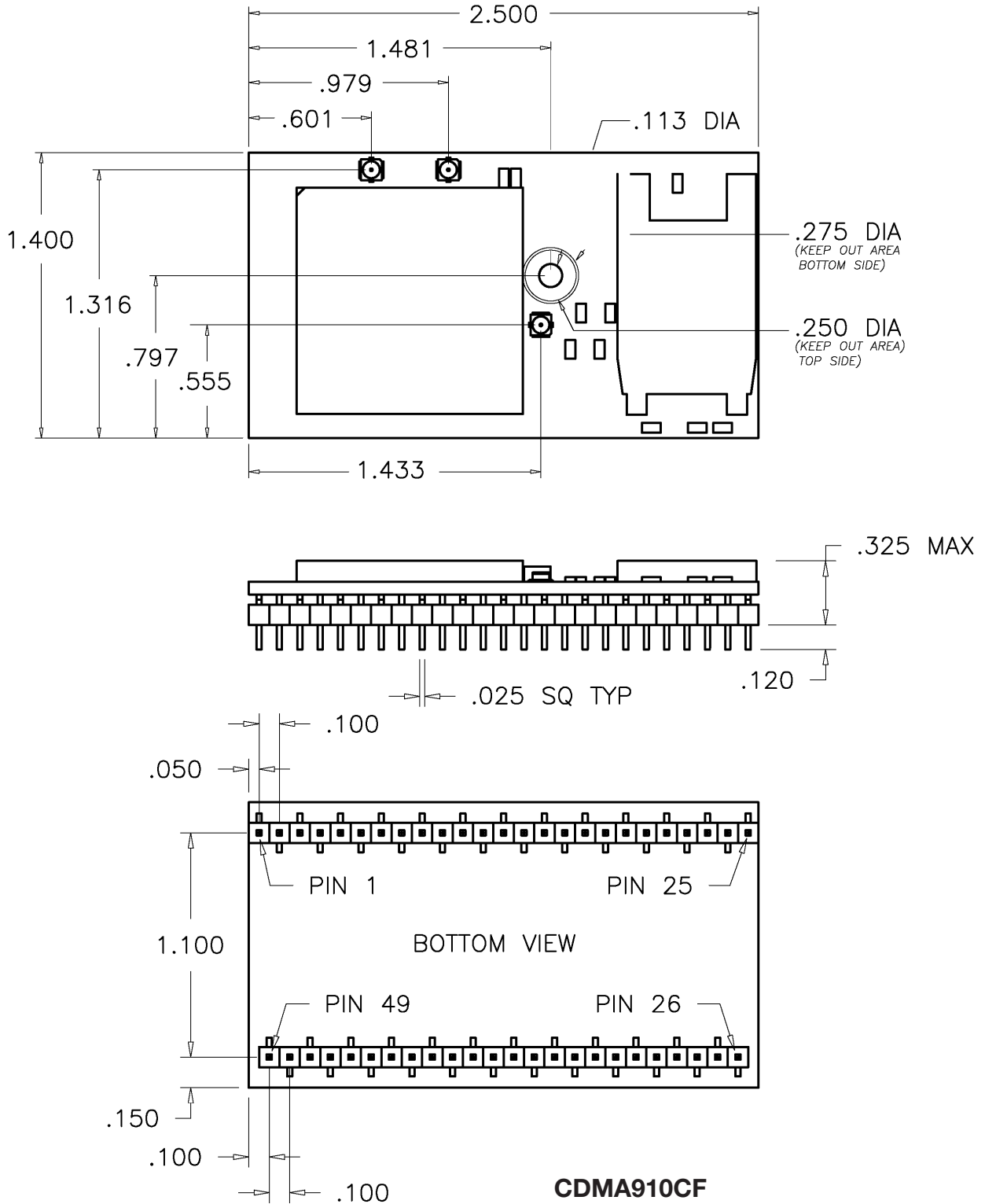

Figure 11 CDMA910CF Mechanical Dimensions

5 CDMA910CF TECHNICAL SPECIFICATIONS continued

5.3 Setting Up a Terminal Emulator for Use With the CDMA910CF modem

5.3.1 Set Up

To interface with the module, connect the serial interface to a PC and use a terminal emulation program such as Microsoft® Hyperterminal. Set the interface parameters as follows:

Baud Rate: 115.2 kbps

Bits: 8

Stop Bits: 1

Parity: None

Hardware Handshaking: Yes

5.3.1.1 Test the Emulator Set Up

Enter AT<cr> from terminal and wait for OK

Note that Autobaud is not supported on the CDMA910CF modem. If you are utilizing the serial interface and you wish to change the baud rate on the module, you must use AT+IPR. You must also change the rate in the host UART (i.e. HyperTerminal) to match the new baud rate. If these do not match you will not be able to send AT commands to the module through the serial port. The modem is by default set to 115.2 kbps.

5.3.1.2 Verify Your Terminal and Firmware Version

Enter AT+CGMM and wait for the response

The response will be the Telit module's model number without a command echo.

Enter AT+CGMR and wait for the response

The response will be the Telit module's current firmware without a command echo.

Please confirm your model and firmware with the one listed in section 2.1

5.3.2 Powering ON/OFF

5.3.2.1 Turn the module ON through the following method:

Pull ON/OFF signal (Pin 19) to ground for three (3) seconds, then release.

The module is fully operational after 4 seconds. Logging onto a network may take longer than this and is outside the control of the Modem.

5.3.2.2 There are two ways to switch OFF the module as described below.

Use the appropriate AT command (AT#SHDN)

Pull ON/OFF signal (Pin 19) to ground for three (3) seconds, then release.

5.3.3 Setting Up Service

5.3.3.1 Provisioning the CF Plug-In Modem

To provision the unit, you will need to contact Sprint, Verizon, Aeris, or an MVNO to set up a service contract.

Please see Janus Application Note Note 111: Provisioning Guide for modem M2M Devices

Contact: Dave Jahr, Janus Remote Communications
djahr@janus-rc.com
630-499-2121

5.3 CDMA910CF GETTING STARTED continued

5.3 Setting Up a Terminal Emulator for Use With the CDMA910CF modem continued

5.3.4 Making a Voice Call

5.3.4.1 Set Up

Voice call mode allows you to use a telephone handset to communicate with a properly equipped subscriber unit.

Set the call mode to voice

Enter `AT+FCLASS=8<cr>` and wait for response OK

Dial the phone number

Enter `ATD <8885551234>; <cr>`

To disconnect the call enter `ATH<cr>`

5.3.5 Sending an SMS

5.3.5.1 Set Up

SMS (Select Message Service) mode allows you to send a text message (max 160 characters) to a SMS capable subscriber unit.

Set the SMS mode to text. This must be entered every power cycle.

Enter `AT+CMGF=1<cr>`

To enter the receiving subscriber unit phone number and message enter:

Enter `AT+CMGS="8885551234"`

Wait for response ">" then enter message text

Enter "ctrl z" <cr> to end the message

5.3.6 Making a Data Call/Socket Dial

5.3.6.1 Set Up

The Packet Data Protocol (PDP) is utilized when making data connections.

Activate the PDP context

Enter `AT#SGACT=1,1,"v", "p"`

Where v is your user ID and p is your password.

If these are not set replace with "", ""

Open the socket connection

Enter `AT#SD=1,0,IPP,IPA,0,0,0`

Look for response "CONNECT". This opens a remote connection via socket

IPP = the remote host port of the server you are trying to connect to. (0 to 65535)

IPA = the IP address of the server you are trying to connect to in the format:

"xxx.xxx.xxx.xxx"

At this point a data session is active and data can be sent from the modem to the remote device and visa versa.

To exit the data session and return to command mode, send the characters "+++" and wait for the OK response

Enter `AT#SH=1` to close the socket

5.3.7 Further Instructions

On utilizing different commands for other applications than those described here, please refer to these reference documents, listed in section 2.1

Telit CE910 AT Commands Reference Guide

Telit CE910 Software User Guide

Please see Janus Application Note Note 111: Provisioning Guide for CF Plug-In M2M Devices

6 DESIGN CONSIDERATIONS

6.1 Minimum Required Module Pin Connects

CDMA Pin Functions

Pin	Signal	Function	Note
1	VBATT	Main power supply	
2	VBATT	Main power supply	
12	GND	Ground	
25	GND	Ground	
26	GND	Ground	
39	GND	Ground	
49	GND	Ground	
9	TXD	Serial data input (TXD) from DTE	
4	RXD	Serial data output to DTE	
11	RTS	Input for request to send signal (RTS) from DTE	2
19	ON/OFF	Input command for switching power ON or OFF (toggle command)	
20	RESET	Reset input	

Note:

1. If the application uses USB as the main interface to the module, this is sufficient to capture any debug or trace data, provided the application can export the diagnostic port externally.
2. RTS must be connected to ground if flow control is not used.
3. USB interface required for local firmware upgrade of Telit radio.

6.2 Debug:

Debug of the CF Plug-In Modems in production

To test and debug the mounting of the module, we strongly recommend test pads on the host PCB. This will allow verification of the connection between the module itself and the application and to test the performance of the module connecting it with an external computer.

Depending on the customer application, these pads include, but are not limited to the following signals:

TXD
RXD
ON/OFF
RESET
GND
VBATT
TX_TRACE
RX_TRACE
PWRMON
USB D+
USB D-
USB V_BUS
USB_ID

APPENDICES

Approvals

Sprint Certification Pending
Verizon Certification
Aeris Certification Pending
FCC Certified
CE Certified

Safety Recommendations (for Information only)

Antenna Care and Replacement

Do not use the modem with a damaged antenna.

Buy the antenna from an approved suppliers list. Using unauthorized antennas, modifications, or attachments could damage the modem and may violate local RF emission regulations or invalidate type approval.

Abbreviations

3GPP	3rd Generation Partnership Project	ITAR	International Traffic In Arm Regulation
AC	Alternating Current	LED	Light Emitting Diode
ADC	Analog To Digital Converter	M2M	Machine To Machine
BER	Bit Error Rate	PBCCH	Packet Broadcast Control Channel
CD	Carrier Detect	PDU	Protocol Data Unit
CDMA	Code Division Multiple Access	RF	Radio Frequency
CSD	Circuit Switched Data	RI	Ring Indicator
CTS	Clear To Send	RSSI	Received Signal Strength Indication
DB	Decibel	RTS	Request To Send
DBFS	Decibels Full Scale	RxD	Received Data
DC	Direct Current	SMS	Short Message Service
DCE	Data Communications Equipment	TTFF	Time To First Fix
DSR	Data Set Ready	TxD	Transmitted Data
DTMF	Dual-tone multi-frequency	UICC	Universal Integrated Circuit Card
DTR	DTE Ready	UMTS	Universal Mobile Telecommunications System
FDN	Fixed Dialing Number	USIM	Universal Subscriber Identity Module
GPIO	General Purpose Input Output	USSD	Unstructured Supplementary Service Data
GPRS	General Packet Radio Service	VSWR	Voltage Standing Wave Ratio
GSM	Global System Mobile	WAAS	Wide Area Augmentation System

CDMA910CF Plug-In Embedded Cellular Modem User Manual



Ordering Information

Ordering Information	Description
CDMA910CF v2.00	CDMA910 CF Plug-In (Sprint)
CDMA910CF v3.00	CDMA910 CF Plug-In (Verizon)
CDMA910CF v4.00	CDMA910 CF Plug-In (Aeris)

Revision History

Revision	Revision Date	Note
P00	06/13/14	Preliminary CDMA910CF Individual CF Plug-In User Manual
P01	07/17/14	Update Block Diagram, USB VBUS Diagram, Misc edits
P02	04/12/17	Updated Product Photo, Temp Range and Contact Information



Division of The Connor-Winfield Corporation

2359 Diehl Road • Aurora, IL 60502

Phone: 630.499.2121 • info@janus-rc.com

www.janus-rc.com