

125 Series FTS125 Disciplined Reference and Synchronous Clock Generator



2111 Comprehensive Drive
Aurora, Illinois 60505
Phone: 630-851-4722
Fax: 630-851-5040
www.conwin.com

D
A
T
A
S
H
E
E
T

General Description

The FTS125 Frequency and Time Standard module is a GPS driven, mixed-signal phase lock loop, providing a 1PPS CMOS output from a Connor-Winfield GPS timing receiver and generating a 10MHz CMOS and a 10MHz SINE output from an intrinsically low jitter voltage controlled crystal oscillator. The FTS125 can lock to a 10MHz reference derived from the on-board GPS receiver or an external 10MHz reference or to an external 1PPS reference. Alarms are provided to indicate Loss-of-Lock, Holdover, and Antenna Fault. The on-board GPS receiver requires an outdoor mounted GPS antenna for the best stability and consistent performance.

The mode control inputs are used to manually switch between references and/or holdover. The user application should monitor the alarm outputs and manually switch modes as needed.

Serial I/O lines provide access to the NMEA messages from the GPS receiver (referenced in the Connor-Winfield's Wi125 User Manual. Contact Connor-Winfield Sales for a copy). The serial I/O lines can be used to access GPS timestamp information, or to verify that the receiver has recovered from an alarm condition. The reset is used to reset the GPS receiver (if needed).



Features

- Phase locked 10.0 MHz output
- 1 PPS output
- 3 selectable references: GPS, External 10MHz or External 1PPS
- Holdover
- Three alarm outputs. (Loss-of-Lock, Holdover and Antenna Fault)
- Serial input and output ports (GPS receiver)
- Master reset
- +3.3 Volt power supply
- Commercial Temp (0-70° C)
- Meets ITU-T G.811 Wander Generation Mask
- Meets ETSI-PRC Wander Generation Mask (with OCXO reference)
- MCX GPS Antenna Connection
- Fixed Position Unit

Bulletin	SG161
Page	1 of 12
Revision	00
Date	14 June 10
Issued By	ENG

Functional Block Diagram

Figure 1

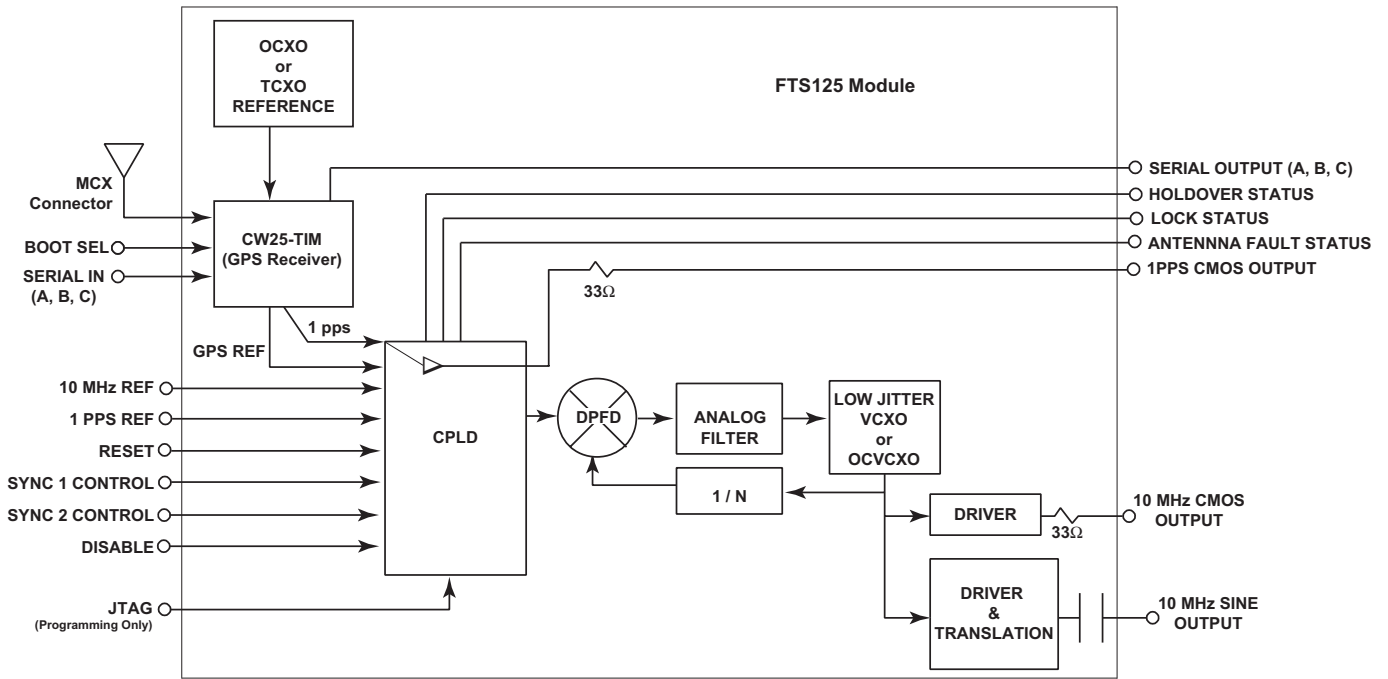

Typical Application

Figure 2

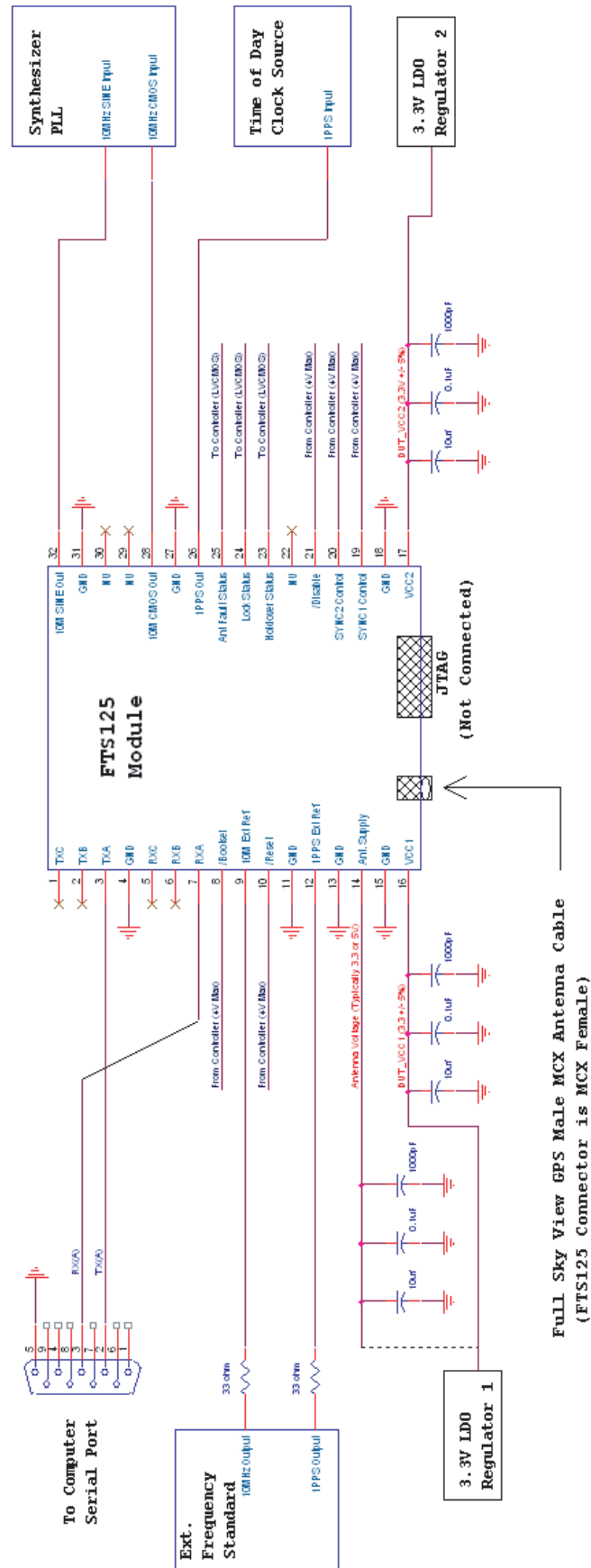

Full Sky View GPS Male MCX Antenna Cable
(FTS125 Connector is MCX Female)

Pin Description

Table 1

Pin #	Pin Name	Description
1	TXC	RS-232 communication transmit signal for UART2 (Optional)
2	TXB	RS-232 communication transmit signal for UART1 (Optional)
3	TXA	RS-232 communication transmit signal for UART0 (Optional)
4	GND	
5	RXC	RS-232 communication receive signal for UART2 (Optional)
6	RXB	RS-232 communication receive signal for UART1 (Optional)
7	RXA	RS-232 communication receive signal for UART0 (Optional)
8	*Bootsel	Normally HIGH - Only pulled low for RS-232 re-programming of GPS software. Default state is pulled high internally.
9	10MHz Ref Input	External LVCMOS 10.0MHz reference (Optional). Default state is pulled high internally.
10	*Reset	Hardware Reset for the GPS timing circuitry. Pull low to reset. Default state is pulled high internally.
11	GND	
12	1PPS Ref Input	External LVCMOS 1PPS reference (Optional). Default state is pulled high internally.
13	GND	
14	Antenna Supply Voltage	Antenna Supply Voltage. Limit continuous current to 45mA Max.
15	GND	
16	VCC1	Supply voltage for GPS timing circuitry.
17	VCC2	Supply voltage for noise clean-up and interfacing circuitry.
18	GND	
19	SYNC1 Control	Lock mode control signal 1. See Table 4 for functional description. Default state is pulled high internally.
20	SYNC2 Control	Lock mode control signal 2. See Table 4 for functional description. Default state is pulled high internally.
21	*Disable	Open/High = enabled outputs. Pull low to disable the 10MHz CMOS and SINE outputs. Default state is pulled high internally.
22	Unused	
23	Holdover Status	High= Unit is in Holdover
24	Lock Status	High= Unit is locked to selected reference.
25	Antenna Fault Status	High= A fault has been detected on Pin 14 (Antenna Supply Voltage)
26	1PPS CMOS Output	1PPS CMOS output provided by the CW25-TIM
27	GND	
28	10MHz CMOS Output	10MHz low jitter CMOS output
29	Unused	
30	Unused	
31	GND	
32	10MHz SINE Output	10MHz AC coupled low jitter SINE output

Absolute Maximum Rating

Table 2

Symbol	Parameter	Minimum	Maximum	Units	Notes
V _{CC}	Power Supply Voltage	-0.3	3.7	Volts	1
V _{IN}	Input Voltage	-0.3	4.6	Volts	1
V _{PREAMP}	Antenna Supply Voltage	2.7	13.2	Volts	1
T _S	Storage Temperature	-30	80	°C	1

Operating Specifications

Table 3

Symbol	Parameter	Minimum	Nominal	Maximum	Units	Notes
V _{CC1}	Supply Voltage 1	3.135	3.3	3.465	V	
I _{CC1}	Supply Current 1					
	with TCXO (CTV, CST)		.200	.300	A	
	with OCXO (COV, COO)		.480	1.2	A	
V _{CC2}	Supply Voltage 2	3.135	3.3	3.465	V	2
I _{CC2}	Supply Current 2					
	with VCXO/TCVCXO (COV, CTV, CST)		.038	.060	A	
	with VCOCXO (COO)		.380	1.0	A	
T _O	Temperature Range	0		70	°C	
t _{JTOL}	Input Jitter Tolerance	30			ns	
t _{AQ_GPS}	GPS Input Acquisition Time					
	TCXO		120		sec	3
	OCXO		150		sec	3
t _{AQ_EXT}	External Input Acquisition Time					
	VCXO		90		sec	3
	OCVCXO		120		sec	3

Oscillator Performance

PLL Option:	VCXO (COV/CTV)	VCTCXO (CST)	OCVCXO (COO)	
F _{CAP}	Capture/Pull-in Range	±50 ppm	±10 ppm	±45 ppb
F _{BW}	Jitter Filter Bandwidth	6 Hz Typ.	0.7 Hz Typ	0.1 Hz Typ.
DC	Duty Cycle	45/55%	45/55	45/55%
RMS	RMS Phase Noise			
	10Hz - 2MHz	20 ps Typ.	1.5 ps Typ	1 ps Typ.
	12kHz - 2MHz	0.5 ps Typ.	0.6 ps Typ	0.6 ps Typ.

Holdover/Wander Generation Performance

4

Reference Option:	Int TCXO (CTV)	Ext TCXO (CST)	OCXO (COO, COV)		
T _{STA}	Temperature Stability	±0.5 ppm	±0.28 ppm	±20 ppb	5
V _{STA}	Vcc Stability	0.1 ppm	20 ppb	±5 ppb	
A _{DAILY}	Daily Aging	-	20 ppb	2 ppb	
A _{YEARLY}	Yearly Aging	2 ppm	-	80 ppb	
	Wander Generation Specification	ITU-T G.811	ITU-T G.811	ETSI-PRC	

NOTES:

- Stresses beyond those listed under "Absolute Maximum Rating" may cause permanent damage to the module. These are stress ratings only and functional operation of the device at these or any other conditions beyond those indicated under "Operating Specifications" is not implied. Exposure to absolute maximum rated conditions for extended periods may affect device reliability.
- Requires external regulation and supply decoupling
- Cold Power-up
- Holdover will be re-calculated with each successful lock. Yearly aging represents 1 continuous year in Holdover.
- Relative to 25°C

Mode Control Table

Table 4

SYNC 1	SYNC 2	Operating Mode
0	0	Force Holdover
0	1	Lock to External 10MHz reference*
1	0	Lock to External 1PPS reference
1	1	(Default) Lock to GPS Signal

* Note: Holdover is not supported in this mode; loss of the 10MHz reference will rail the PLL output until the reference returns or another mode is selected.

Input And Output Characteristics

Table 5

LVCMOS Inputs and Outputs

Symbol	Parameter	Minimum	Maximum	Units	Notes
V _{IH}	High Level Input Voltage	1.7	4.0	V	
V _{IL}	Low Level Input Voltage	-0.5	0.8	V	
V _{OH}	High Level Output Voltage	2.4		V	
V _{OL}	Low Level Output Voltage		0.4	V	
C _O	Output Capacitance		10	pF	

10MHz Sine Output

Symbol	Parameter	Typical	Units	Notes
	Load	50	ohms	
	Output Power	9	dB _m	
	Total Harmonic Distortion	2.2	%	

GPS Receiver Specifications

Table 6

Parameter	Specifications	Notes
Acquisition/Tracking Sensitivity	-155dBm/-156dBm	
Acquisition Time:		
Hot Start w/ Network Assist	Outdoor: <2 sec Indoor(-148dBm) <5 sec	
Stand Alone	Cold <45 sec Warm: <38 sec Hot: <5 sec Re-acquisition: <1sec (90% confidence)	
Supported Protocols	Network Assist, NMEA 0183	

Reset Generation (I/O pin 10 - RESET)

The power-on-reset for the FTS125 is generated on-board. If it is desired to extend the power-on-reset signal or provide a manual reset of the GPS receiver, pull this signal low.

Antenna Requirements

Table 7

Parameter	Notes
The FTS125 antenna connector is an MCX (female)	
The antenna supply voltage provided to Pin 14 must be within the range of 2.7 to 13.2V (AMR); the antenna must be able to operate at this voltage	
The antenna's continuous current draw must be <=45mA	
The antenna must have a full sky view for optimal receiver performance	
An active antenna with a minimum 10dB gain (including cable loss) should be used	

Standard 125 Series models are designed for fixed position operation only. Contact Connor-Winfield Sales for mobile application model offerings

Phase Noise

Figure 2

Phase Noise:

Offset Frequency (Hz)	COO (dBc/Hz)	CST (dBc/Hz)	CTV (dBc/Hz)
10	-105	-90	-70
100	-132	-125	-105
1k	-145	-146	-135
10k	-150	-152	-145
100k	-152	-153	-152
1M	-154	-155	-158

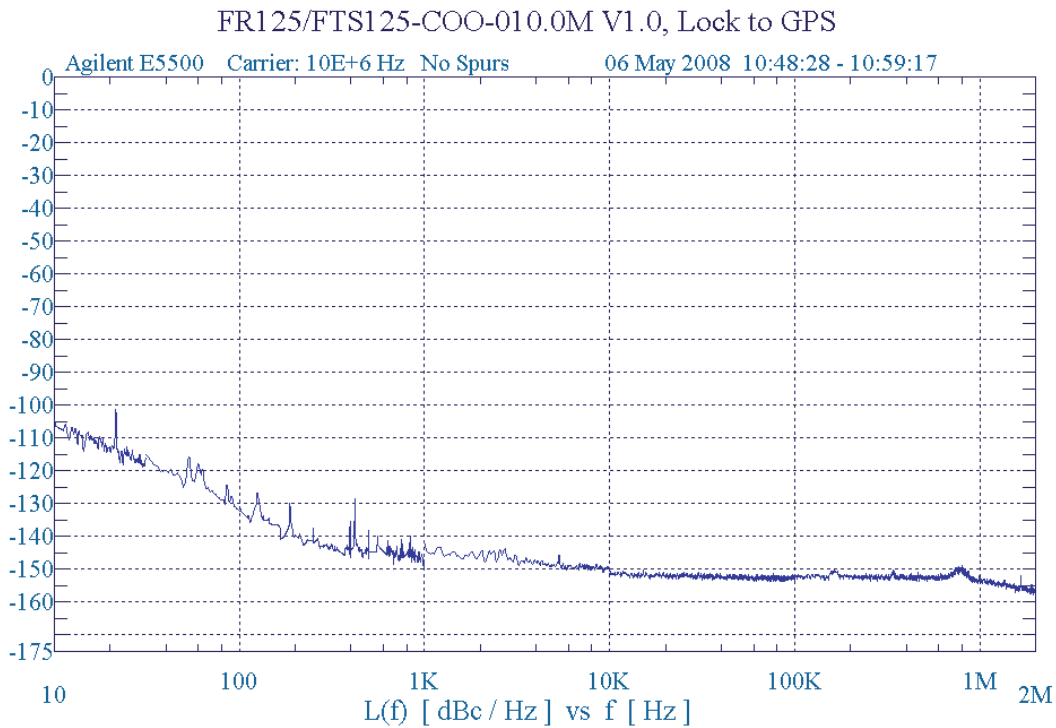

Allan Variance – CTV

Figure 3

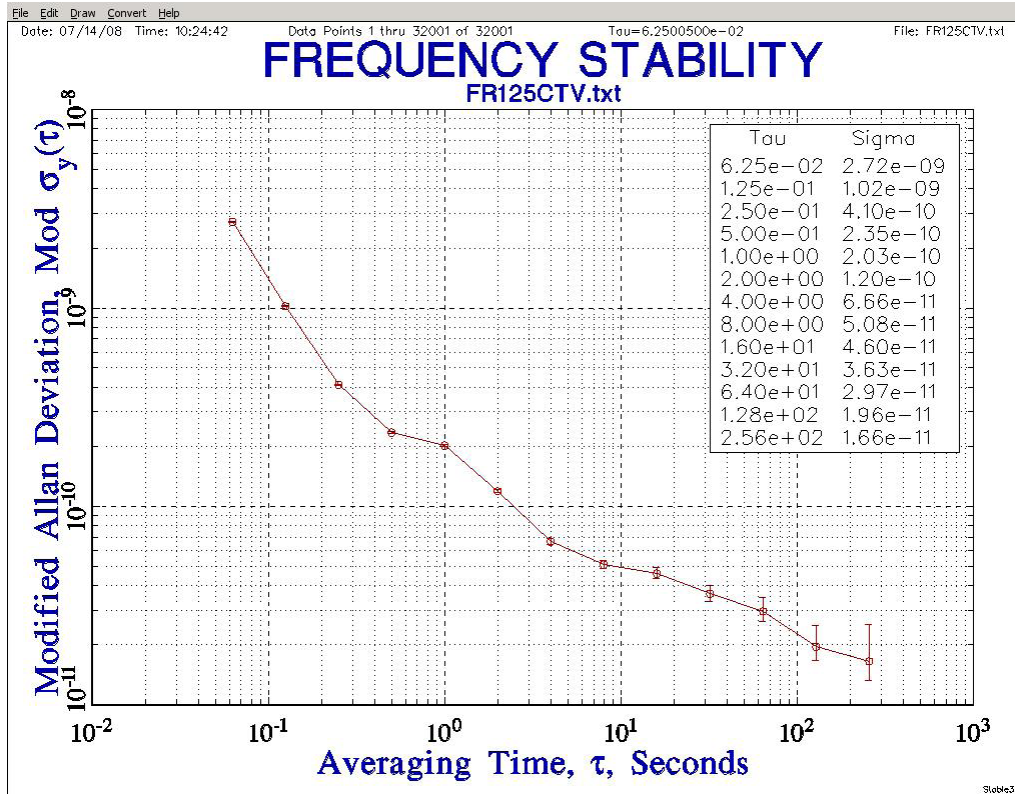

Allan Variance – COO

Figure 4

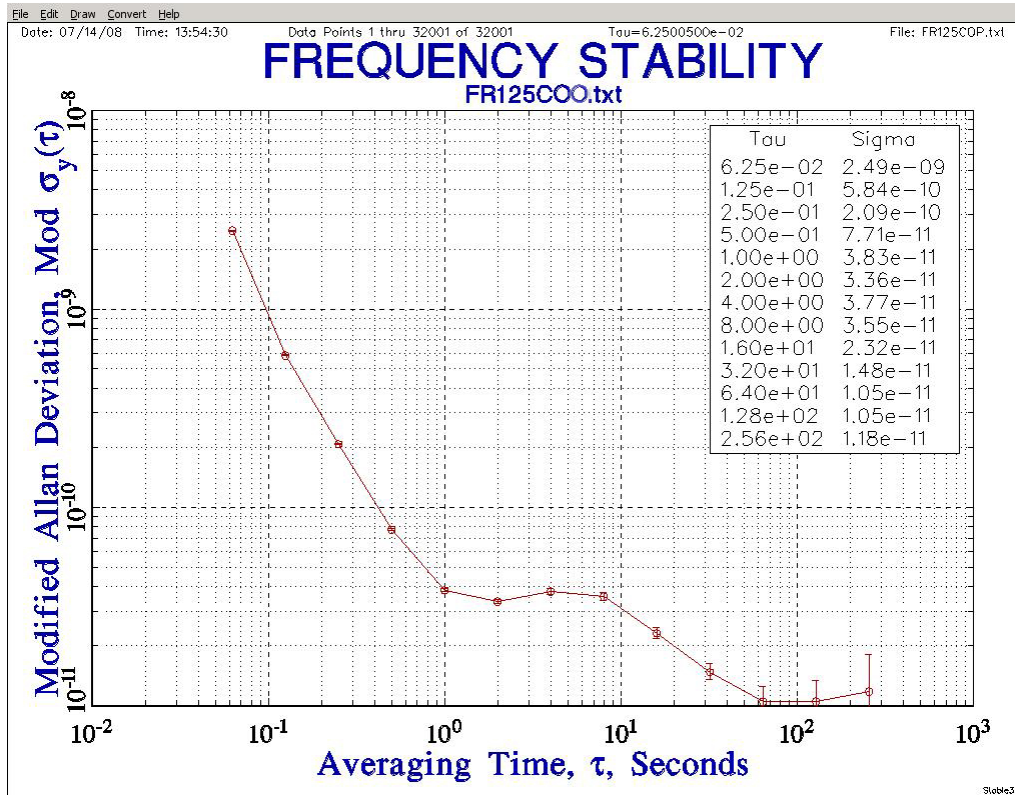

Wander Generation Plot – CTV versus G.811 Wander Generation Mask

Figure 5

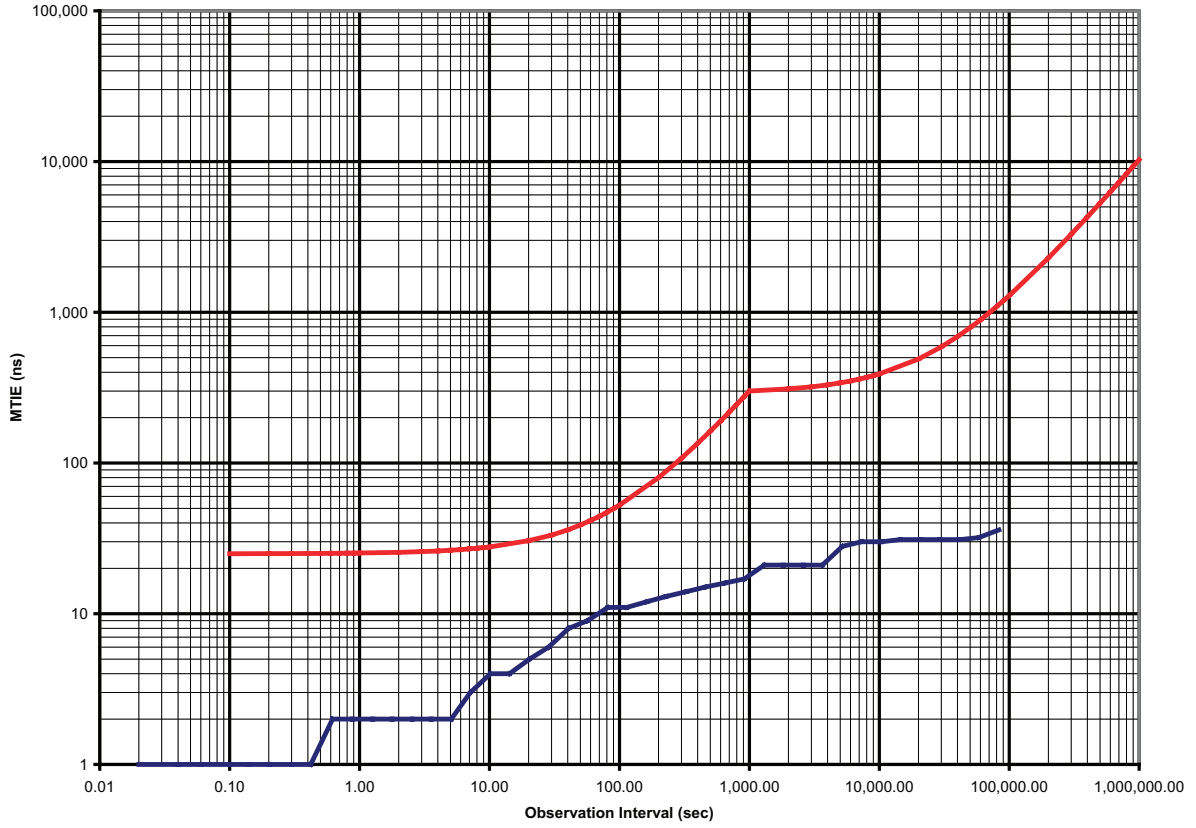

Wander Generation Plot – COO versus ETSI-PRC Wander Generation Mask

Figure 6

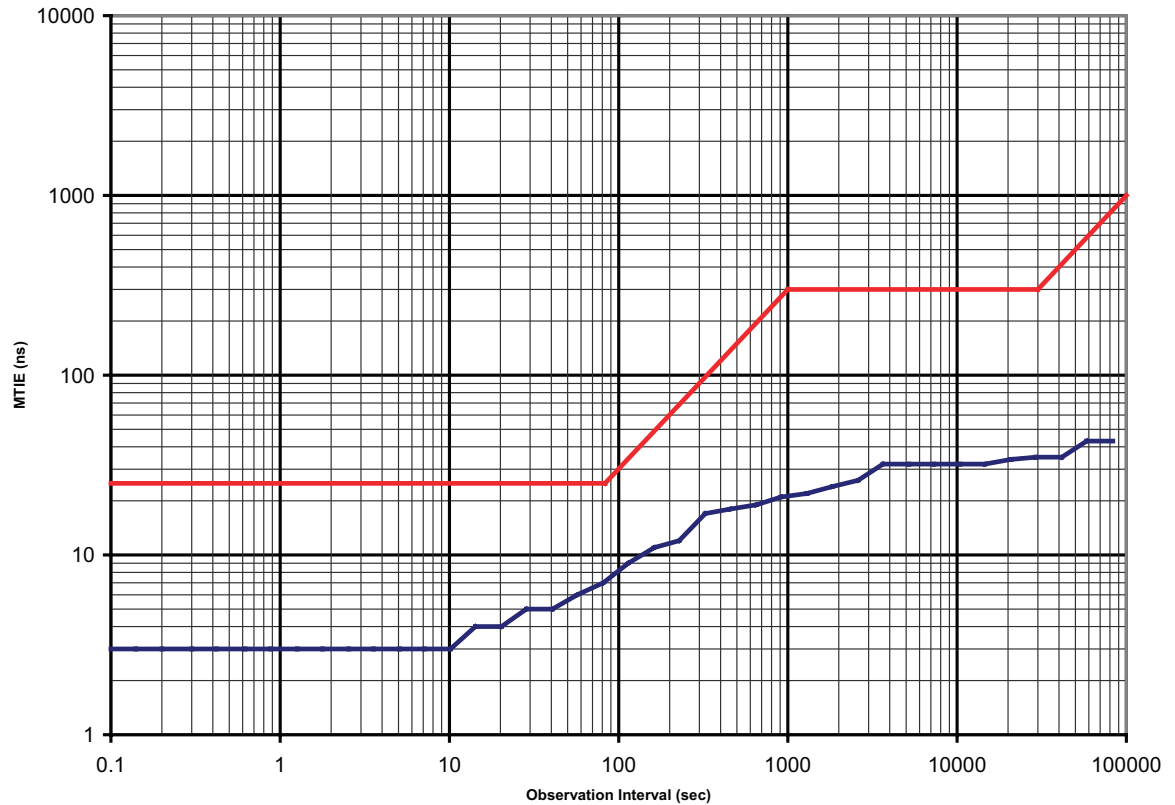

Package Dimensions

Figure 7

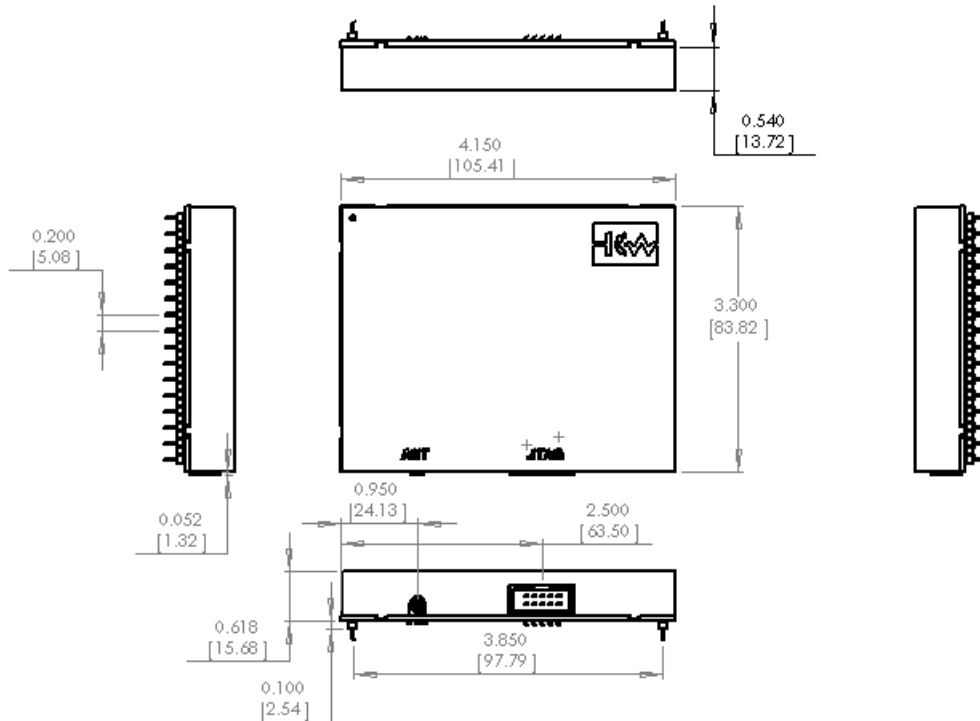

Recommended Footprint Dimensions

Figure 8

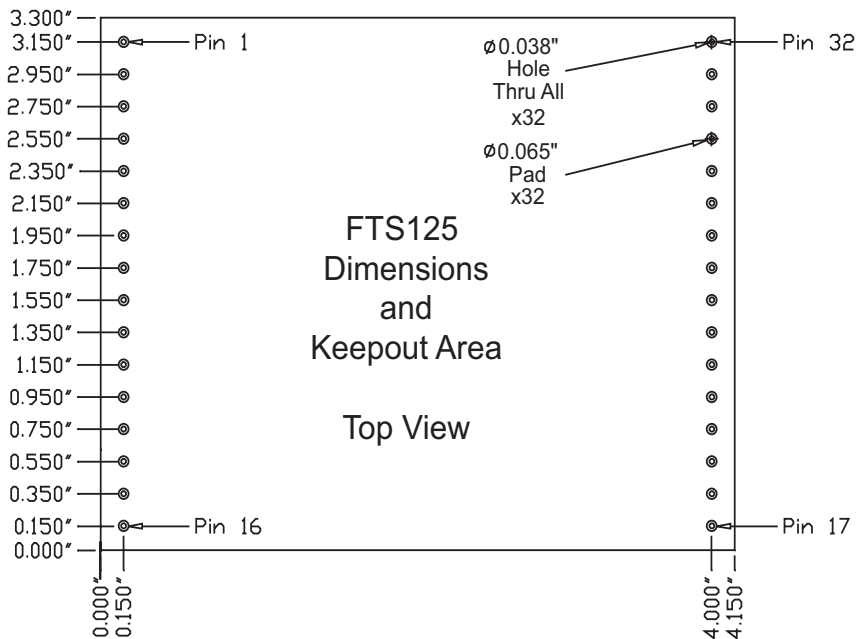

Ordering Information

Ex: FTS125-COO-010.0MHz

FTS125	C	O	O	-010.0M
	Temp Range	CW25 Reference	PLL Oscillator	Output Frequency
	C = 0-70degC	O = OCXO	O = OCVCXO *	
		T = TCXO	V = VCXO	
		S = Tighter Tolerance TCXO	T = VCTCXO	

* CTO Option is not available



2111 Comprehensive Drive
Aurora, Illinois 60505
Phone: 630-851-4722
Fax: 630-851-5040
www.conwin.com

Revision	Revision Date	Note
P00	5/12/08	Preliminary Release
P01	6/19/08	Temperature Range Edit
P02	7/17/08	Plots & Graphs added
P03	8/25/08	Acquisition/Tracking Edit
P04	9/15/08	Indoor Temp Revision
P05	11/10/08	MCX Info added & Block Diagram Update
P06	06/30/09	Update for New Model Number
P07	12/10/09	Antenna Requirement & Typ Application Updates
P08	01/08/10	Fixed Unit Clarification & GPS Reference Information
00	06/14/10	125 Series Update and Public Release